

# INSTRUCTION MANUAL

ACTIVE POWER TRANSDUCER

WTT2-92A-12

WTT2-92A-13

WTT2-92A-33

WTT2-92A-34

[ MODEL B ]

## Introduction

Thank you for purchase of DAIICHI ELECTRONICS product.  
Please read this instruction manual carefully before use. Keep this manual for future reference.  
Please contact with us in case this manual is lost or damaged.

## Safety precautions

### ■ Environment conditions

- Please be sure to use this product in a place that meets the following conditions.  
In places that do not meet this condition, malfunctions and failures, and performance and product life may be reduced.
  - Within the range of ambient temperature -10 to 55°C, humidity 5 to 90% RH.
  - Environment with low corrosive gas, dust, salt and oil smoke. (Corrosive gas : SO<sub>2</sub>/H<sub>2</sub>S, etc.)
  - Environment that is not affected by vibration or shock.
  - Environment with less external noise.
  - Altitude 2000m or less.
- If the input to this product is an inverter output (cycle control, SCR phase angle control, PWM control, etc.), the measurement error will be large.

### ■ Outdoor use conditions

- These products are not a dust proof, water proof, and splash proof construction.  
Please avoid the place where dust is generated, and install it in a place where it will not be exposed to rain or water droplets. (Protection class IP30)
- Please do not install in the place where sunlight hits directly.  
Discoloration and degradation of a name plate, and deformation of the case by the surface temperature rise may occur.
- If the average daily temperature around this product exceeds 40°C, the service life may be shortened.

### ■ Mounting and wiring

Please refer to this instruction manual for mounting and the wiring.

 <b>CAUTION</b>	<ul style="list-style-type: none"> <li>● Please refer to connection diagram for the wiring.</li> <li>● Please avoid hot line work.</li> <li>● Please use an electrical wire size suitable with the rated current.</li> <li>● Please check the tightening of the screw.</li> <li>● Please attach the terminal cover to prevent electric shock.</li> </ul>
--	--

### ■ Maintenance and inspection

- Inspection during energization is dangerous.
- This product has no parts to replace during regular inspections.
- Check that the wiring and screws are not loose.
- Please wipe off lightly with the dry soft cloth. Please do not use the organic solvent, chemicals, cleaners, etc., such as an alcohol, for cleaning.

### ■ Storage

Please store in a place that meets the following conditions.

- The ambient temperature within -40 to +70°C (storage temperature), humidity 5 to 90% RH.
- Daily average temperature 40°C or less.
- Places free of dust, corrosive gas, salt and oily smoke.
- Location that is not affected by vibration and shock.
- Aluminum electrolytic capacitors are used in products. Please energize the power supply within one year after purchase.

**■ Countermeasures against troubles**

If trouble occurs within the warranty period, DAIICHI ELECTRONICS will repairs this product.

**■ Disposal**

Please dispose this product as industrial waste (non-combustible).  
Mercury parts and a nickel-cadmium battery are not used for this product.

**■ Warranty period**

The warranty period of the product is one year after the date of delivery.

**■ Warranty scope**

In the case that a defect is found in our product during the warranty period due to our responsibility, we will replace the defective part and repair.

However, we will not be liable if the faults or defects are under any of the following items.

- When the faults or defects are resulted from the modification or repair carried out by any other entity than our company.
- Failure caused by violating various conditions regarding use, storage, etc. specified by the supplier.
- When the faults or defects are caused by a reason not belongs to purchased or delivered products.
- Damage or malfunction due to relocation or other transportation, movement or dropping.
- In case that the faults or defects are resulted from force majeure such as fire or abnormal voltage and natural calamity or disaster.

Our company shall not be liable for compensation of damages caused by any reason which is not our responsibility, loss opportunity, loss profits incurred to the user, special damages and consequential damages whether foreseeable or not, or damages not relating to our products.

**■ Replacement cycle of the product**

We recommend updating the product for 10 years as a rough standard.

**■ Change of instruction manual written contents**

This instruction manual changes written contents without a notice by product improvement etc.

## Contents

Safety precautions .....	1
1. Features of product .....	4
2. Outline dimension .....	4
3. Bundled items .....	4
4. Mounting method .....	4
5. Connection .....	6
6. Handling explanation .....	7
7. Specification	
7.1 Rating .....	7
7.2 Performance .....	8
7.3 Electrical strength, Mechanical strength .....	9
7.4 Noise immunity .....	9
7.5 EMC .....	10
7.6 Structure and environmental conditions .....	11
7.7 Technical standards .....	11
8. Input and output relationship .....	12
9. Calibration .....	12
10. Type composition .....	13

## 1. Features of product

- Complied to JIS C 1111 : 2019 and IEC 60688 : 2012
- Free power supply specifications compatible with 80 to 264 VAC and 80 to 264 VDC, and 24 VDC/48 VDC power supply specifications are available.
- Power consumption and weight have been reduced by about 50% compared to our conventional products.
- Compatible with two types of mounting methods for IEC/DIN rail mounting and wall mounting.

## 2. Outline dimension

Please refer to the wiring diagram for the terminal arrangement.

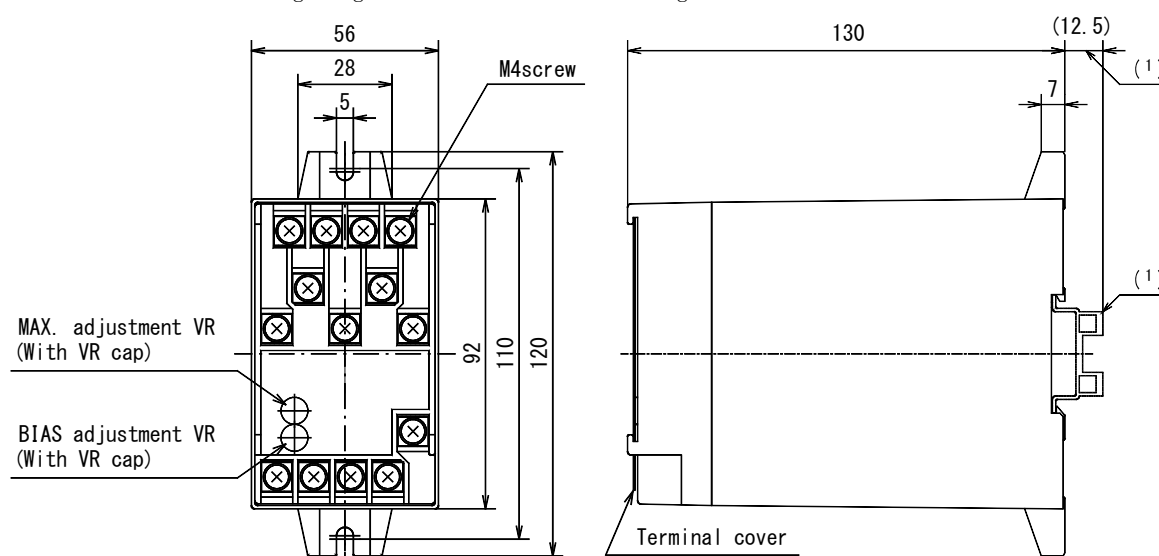

Note<sup>(1)</sup> Dimensions when IEC/DIN rail (height 15mm) is installed. (Please use a rail with a width of 35mm)  
The terminal cover is standard equipment.

## 3. Bundled items

- ① Inspection certificate : 1 (Packed in an envelope)
- ② Terminal screw in a bag.
 

WTT2-92A-12	M4 screw 4-piece set : 1, M4 screw 5-piece set : 1
WTT2-92A-13	M4 screw 5-piece set : 1, M4 screw 7-piece set : 1
WTT2-92A-33	M4 screw 5-piece set : 1, M4 screw 7-piece set : 1
WTT2-92A-34	M4 screw 7-piece set : 2

## 4. Mounting method

Please install indoors in a place with low mechanical vibration, dust, and corrosive gas. And, please select indoors that are not affected by a strong electromagnetic field by large current bus, saturable reactor etc. in the vicinity. There is no restriction on mounting position. Mounting can be done on 35mm width DIN rail mounting or screw mounting. For screw mounting, please install with M4 screw or M5 screw. (However, the screw is not attached. The tightening torque of a screw, M4 : 1.00 to 1.30N·m, M5 : 2.0 to 2.5N·m) There is no particular rule for the side-by-side spacing. Considering heat dissipation and wiring space, please leave 90mm or more space between the top and bottom. Please leave space between terminal and metal panel for 10mm or more.

<Caution> Be sure to turn off the power and input signals before installing or removing the product to prevent danger.

Combination mounting dimension example (unit : mm)

■ Screw mounting

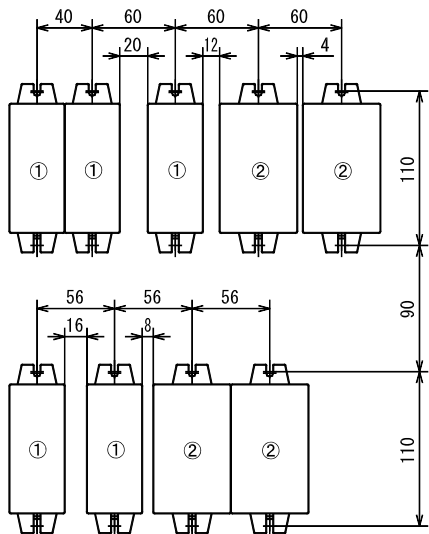

■ IEC/DIN rail mounting

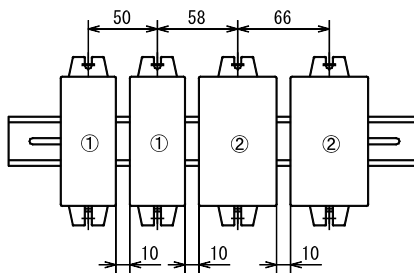

- ① : 40mm width transducer.
- ② : 56mm width transducer.

Please use rail of IEC, DIN technical standard 35mm width rail (strong type).

《Recommendation product》 Fuji Electric Co., Ltd.  
TH35-15AL

■ How to install this product in a IEC / DIN rail.

The claw of the upside of the slot for rail mounting in the bottom of this product is put in a rail. This product is fixable by pushing in the direction of an arrow below.

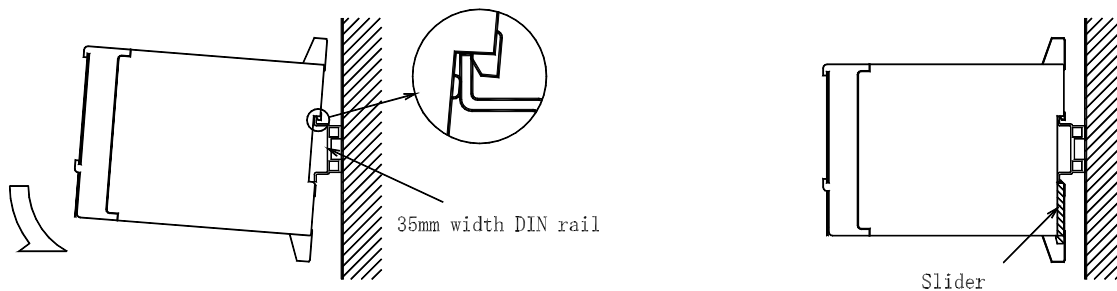

■ How to remove this product from the IEC / DIN rail.

Please insert a flathead screwdriver in the hole where a slider is square. Next, a slider is lowered in the direction of an arrow. This product can be removed from the rail by pulling it up in the direction of the arrow. However, the case may be damaged if this product is pulled up without lowering a slider completely.

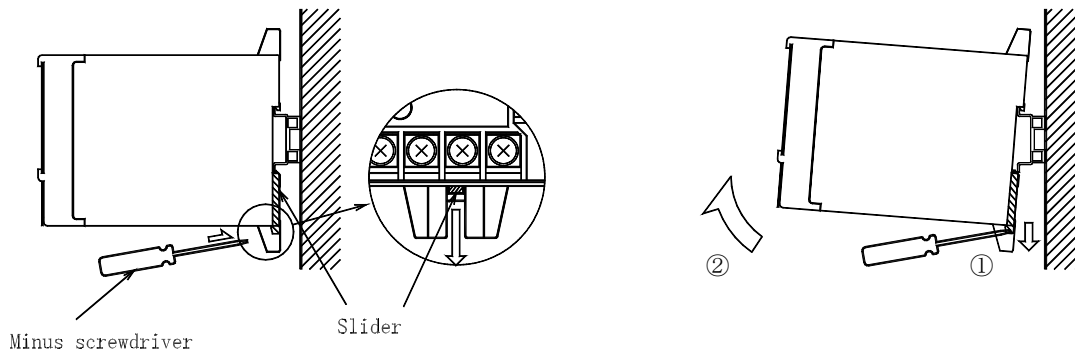

## 5. Connection

Refer to the terminal name on the front name plate of the main unit, and connect according to the wiring diagram below or the wiring diagram name plate on the lower side of the main unit.

Use the included M4 screws to connect the auxiliary power supply, input voltage, input current, output, and ground terminals.

[Applicable solderless terminal] Solderless terminal for M4 screw  
 Outer diameter of terminal, 8.5mm or less  
 Tightening torque : 1.0 to 1.3 N·m

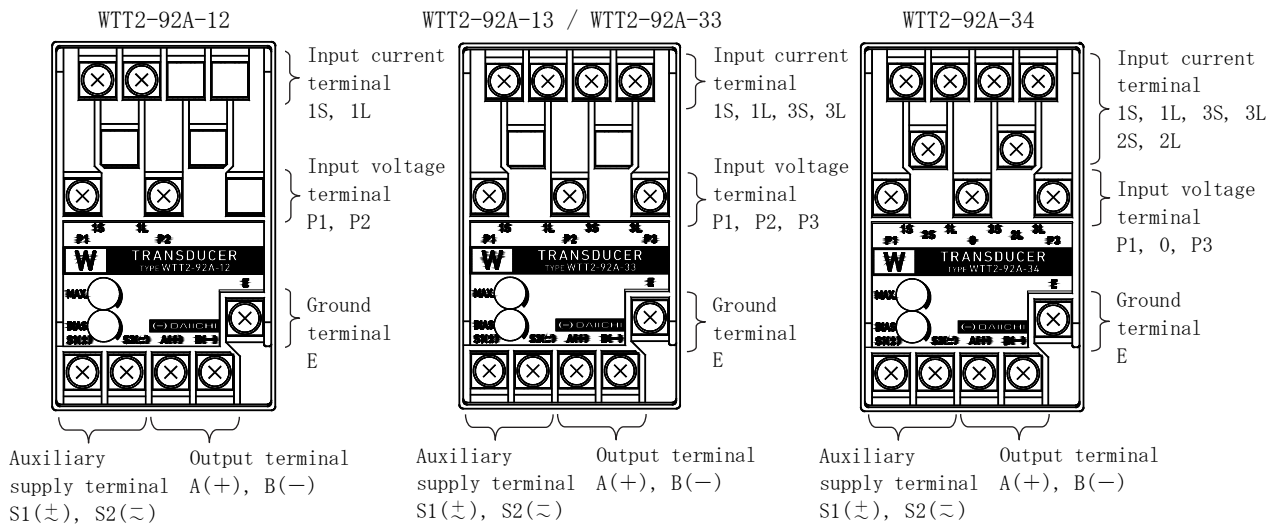

### ■ Connection diagram

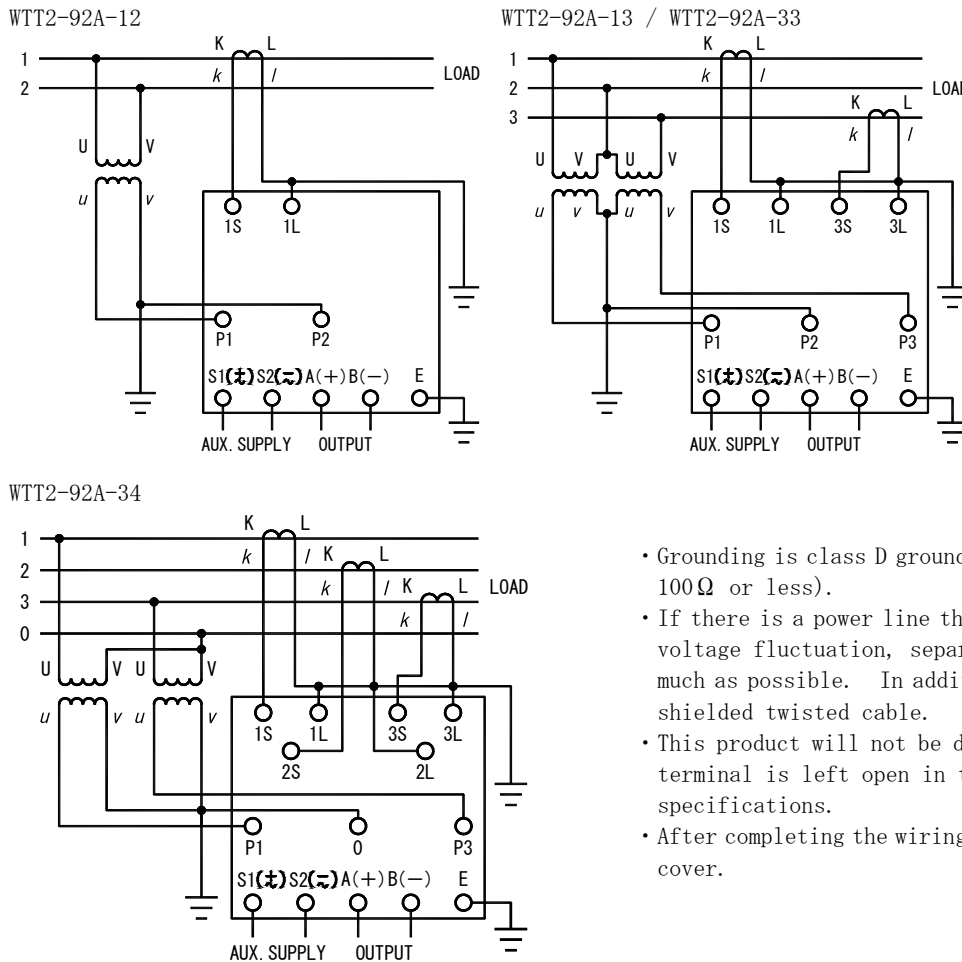

- Grounding is class D grounding (grounding resistance 100Ω or less).
- If there is a power line that causes noise or a sharp voltage fluctuation, separate the output wiring as much as possible. In addition, use twisted cable or shielded twisted cable.
- This product will not be damaged even if the output terminal is left open in the current output specifications.
- After completing the wiring work, attach the terminal cover.

## 6. Handling explanation

Please handle it correctly after paying attention to the following points.

- (1) When applying the auxiliary power supply and input, check that the voltage and input signal of the auxiliary power supply conform to the specifications of this product.
- (2) Make sure that the external wiring is connected to the specified terminal position (listed on the nameplate).
- (3) Please use the output load within the output load range indicated on the name plate.  
If the output load range is exceeded, not only will the output error, but the product will be burdened. Especially for voltage output products, do not short-circuit the output.  
This product will not be damaged even if the output terminal is left open in the current output specifications. However, a voltage of about 15V is generated.
- (4) The output adjustment range is BIAS :  $\pm 5\%$  of the output span, MAX. :  $\pm 5\%$  of the output span.  
Use only when adjustment is required for matching with connected devices.
- (5) The output value when only the auxiliary power supply is applied or when the auxiliary power supply and voltage input are applied is the output equivalent to the input 0kW.

## 7. Specification

### 7.1 Rating

Item		Specification	
Input	Active power	0 to 500W 0 to 1kW 0 to 2kW -500 to 500W -1 to 1kW -2 to 2kW	( <sup>3</sup> ) Please specify
	Rated voltage	AC110/ $\sqrt{3}$ V 50/60Hz AC110V 50/60Hz AC220/ $\sqrt{3}$ V 50/60Hz AC220V 50/60Hz	( <sup>2</sup> )( <sup>3</sup> ) Please specify
	Rated current	AC 1 A 50/60Hz AC 5 A 50/60Hz	( <sup>3</sup> ) Please specify
	Power consumption	Voltage circuit : 0.2VA (AC110V), 0.5VA (AC220V) Current circuit : 0.2VA	
Output (Output load range)		DC0 to 5V (600 $\Omega$ or more) DC1 to 5V (600 $\Omega$ or more) DC-5 to 5V (600 $\Omega$ or more) DC0 to 1mA (10k $\Omega$ or less) DC4 to 20mA (550 $\Omega$ or less) DC-1 to 1mA (10k $\Omega$ or less)	( <sup>3</sup> ) Please specify
Auxiliary supply	Power supply range	AC80 to 264V 50/60Hz DC80 to 264V DC20 to 57V	AC/DC power supply Please specify
	Power consumption	2.5VA (AC100/110V) , 3.5VA (AC200/220V) 1.5W (DC100/110V, DC200/220V, DC24V, DC48V)	
	Inrush current (Time constant)	AC110V : 1.3A or less (2.8ms) AC220V : 2.5A or less (2.8ms) DC110V : 0.9A or less (2.8ms) DC220V : 1.8A or less (2.8ms) DC24V : 1.5A or less (5.3ms) DC48V : 3.1A or less (5.3ms)	

Note(<sup>2</sup>) Three-phase four-wire is in balanced (phase voltage) positive phase sequence.

Note(<sup>3</sup>) Refer to the specification code for other ratings.



## 7.2 Performance

Item	Specification
Class index	0.5
Response time	1 second or less
Ripple	1%p-p or less
Fluctuation value of influence due to ambient temperature	Usage group I <ul style="list-style-type: none"> <li>• Within the class index at 10 to 35°C</li> <li>• Within two times the class index at 0 to 45°C</li> <li>• Within three times the class index at -10 to 55°C</li> </ul>
Fluctuation value of influence due to input amount distortion	Within two times the class index at 20% of the 3rd harmonic The error may be large in the measurement at the following inverter output. <ul style="list-style-type: none"> <li>• Cycle control</li> <li>• PWM inverter</li> <li>• SCR phase angle control</li> </ul>
Adjustment range	The output adjustment range is BIAS : $\pm 5\%$ of the output span, MAX. : $\pm 5\%$ of the output span. Use only when adjustment is required for matching with connected devices.
Low input cut	None
Output limiter	-20%, 120% (Power receiving input : % of output span on the power receiving side) <ul style="list-style-type: none"> <li>• For 4 to 20mA output, 0.8mA, 23.2mA</li> <li>• For <math>\pm 5V</math> output, -7V, 7V</li> </ul> -20%, 120% (Power receiving / Power transmission input : % of output span on the power receiving side or power transmission side) <ul style="list-style-type: none"> <li>• For 4 to 20mA output, 2.4mA, 21.6mA</li> <li>• For <math>\pm 5V</math> output, -6V, 6V</li> </ul>
Operation method	Time division multiplication method

### 7.3 Electrical strength, Mechanical strength

Item	Specification		
Insulation resistance	Between electric circuit and case (ground).		
	Between auxiliary supply terminals and input, output terminals.	50M $\Omega$ or more at DC500V	
	Between input terminals and output terminals.		
Between electric circuit and case (ground).			
Voltage test (Power frequency withstand voltage)	Between auxiliary supply terminals and input, output terminals.	AC2210V (50/60Hz) 5 seconds or AC2000V (50/60Hz) 1 minute	
	Between input terminals and output terminals.		
	Between auxiliary supply, input terminals and case (ground). (Output circuits are grounded)		
Impulse voltage test	Between auxiliary supply terminals and input terminals. (Other circuits are grounded)	5kV 1.2/50 $\mu$ s (Both positive and negative polarity, for 3 times each)	
	Between input terminals and auxiliary supply terminals. (Other circuits are grounded)		
	Between voltage input terminals. (Other circuits are grounded)		
	Between auxiliary supply terminals. (Other circuits are grounded)		
	Between input terminals and auxiliary supply terminals. (Other circuits are grounded)		
Continuation over-input	Input	1.2 times continuation of rated voltage, rated current.	
	Aux. supply	1.2 times continuation of rated voltage (AC power supply, DC200/220V, DC24V)	
		1.3 times continuation of rated voltage (DC100/110V)	
		DC57V continuous (DC48V)	
Short time over-input	Input	2 times 10 seconds of rated voltage.	once
		2 times 1 second of rated voltage.	10 times, 10 second intervals
		40 times 1 second and 20 times 4 seconds and 10 times 16 seconds of rated current.	2 times, 1 minute intervals
		10 times 1 second of rated current.	5 times, 5 minute intervals
		1.5 times 30 minutes of rated current.	once
	Aux. supply	1.5 times 10 seconds of rated voltage.	once
Vibration	JIS C 60068-2-6 Sweep frequency range : 10 to 55 to 10Hz, Displacement amplitude (one-sided amplitude) : 0.15mm, Number of sweep cycles : 10 times		
Shock	JIS C 60068-2-27 Peak acceleration : 500m/s <sup>2</sup> (when screw is installed), 300m/s <sup>2</sup> (when IEC/DIN rail is installed)		

### 7.4 Noise immunity

Item	Specification	
Damped oscillatory wave immunity test JEA B-402	Error within $\pm 10\%$ when peak voltage 2.5kV, frequency 1MHz $\pm 10\%$ , applied 3 times for 30 seconds. • Auxiliary supply circuit (Normal / Common) • Voltage input circuit (Normal / Common) • Current input circuit (Common)	
Square impulse immunity test JEA B-402	Error within $\pm 10\%$ when noise (1 $\mu$ s, 100ns width) is repeatedly applied for 5 minutes. • Auxiliary supply circuit (Normal / Common) Over 1.5kV • Voltage input circuit (Normal / Common) Over 1.5kV • Current input circuit (Common) Over 1.5kV • Output circuit (Induction) Over 1.0kV	
Radio wave immunity test	Error within $\pm 10\%$ when radio waves (5W) in the 150MHz and 400MHz bands are intermittently irradiated at 1m, and radio waves from mobile phones and wireless LAN (2.4GHz, 5GHz) at 0.5m.	
Electrostatic discharge immunity JEA B-402	Conducted under normal usage conditions. Air discharge : 15kV, Contact discharge : 8kV, Error within $\pm 10\%$ .	

## 7.5 EMC

Item	Specification				
Electrostatic discharge immunity test	Contact discharge ±4kV (Charge voltage) Air discharge ±8kV (Charge voltage)	Performance standard : B	After test : Within inherent error	EN61000-6-2 EN61000-4-2	
Radiated, radio-frequency, electromagnetic field immunity test	Frequency : ① 80 to 1000MHz ② 1.4 to 2.0GHz ③ 2.0 to 2.7GHz Field strength : ① 10V/m ② 3V/m ③ 1V/m Amplitude modulation : 80%AM (1kHz)	Performance standard : A	During testing : Within ±20% error After test : Within inherent error	EN61000-6-2 EN61000-4-3	
Electrical fast transient / burst immunity test	Power port (DC)	±2.0kV	Performance standard : B	After test : Within inherent error	EN61000-6-2 EN61000-4-4
	Power port (AC)	±2.0kV			
	Signal port	±1.0kV			
Surge immunity test	Power port (DC)	Line to ground ±0.5kV Line to line ±0.5kV	Performance standard : B	After test : Within inherent error	EN61000-6-2 EN61000-4-5
	Power port (AC)	Line to ground ±2.0kV Line to line ±1.0kV			
	Signal port	Line to ground ±1.0kV			
Immunity to conducted disturbances, induced by radio frequency fields	Frequency : 0.15 to 80MHz Voltage level : 10V, 80%AM (1kHz)	Performance standard : A	During testing : Within ±20% error After test : Within inherent error	EN61000-6-2 EN61000-4-6	
Power frequency magnetic field immunity test	Frequency : 50/60Hz Field strength : 30A/m	Performance standard : A	During testing : Within ±20% error After test : Within inherent error	EN61000-6-2 EN61000-4-8	
Voltage dips, short interruptions and voltage variations immunity tests (AC power supply port)	Residual voltage : 0%, 1 cycle	Performance standard : B	After test : Within inherent error	EN61000-6-2 EN61000-4-11	
	Residual voltage : 40%, 10/12 cycle	Performance standard : C	After test : Within inherent error		
	Residual voltage : 70%, 25/30 cycle				
	Residual voltage : 0%, 250/300 cycle				
Electromagnetic radiation disturbance	Frequency band 30 to 230MHz, 10m distance : 40dB (μV/m) or less Frequency band 230 to 1000MHz, 10m distance : 47dB (μV/m) or less				
Terminal interference voltage	Power port (AC) : Frequency band 0.15 to 0.5MHz, Quasi-peak : 79dB or less, Average : 66dB or less Frequency band 0.5 to 30MHz, Quasi-peak : 73dB or less, Average : 60dB or less			EN61000-6-4 EN55011 classA, Group1	
Performance standard A : During and after the test the equipment shall be able to continue operation as specified.					
Performance standard B : The equipment shall be able to continue operation as specified after the test. However, performance degradation during testing is allowed.					
Performance standard C : Temporary loss of function is allowed, but the function can be self-healing or can be recovered by operation of the control device.					

## 7.6 Structure and environmental conditions

Item	Specification
Material	BOX : ABS(V-0), Terminal board : ABS(V-0), Terminal cover : Polycarbonate
Color	Munsell N1.5 (Black)
External dimensions	56×120×130mm (W×H×D)
Mass	Approx. 400g
Protection rating	IP30
Operating temperature and humidity limits	-10 to 55°C , 5 to 90% RH (Non condensing)
Storage temperature limits	-40 to 70°C
Product warranty period	One year period

## 7.7 Technical standards

Item	Specification
Transducer	JIS C 1111 : 2019 IEC 60688 : 2012
CE marking	EMC Directive 2014/30/EU EN 61000-6-2, EN 61000-4-2, -3, -4, -5, -6, -8, -11 EN 61000-6-4, EN 55011 classA, Group1 Low Voltage Directive 2014/35/EU EN 61010-1 RoHS Directive 2011/65/EU+(EU)2015/863 EN IEC 63000
Safety	IEC 61010-1 Measurement Category III, Maximum use voltage : 300V, Pollution degree 2

## 8. Input and output relationship

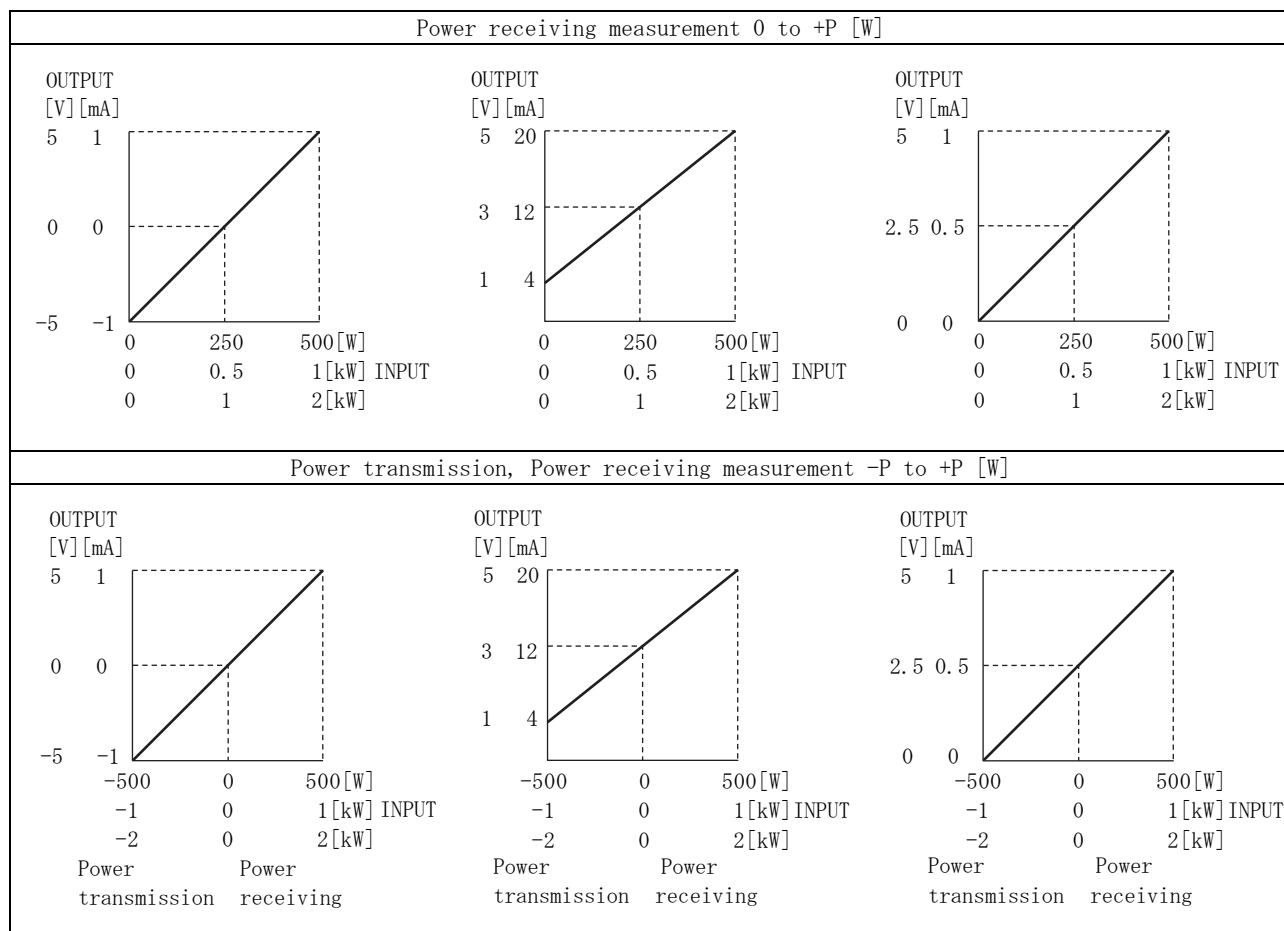

## 9. Calibration

Because this product is adjusted, there is not need of calibration especially.

However, if discrepancy arises in an output in long-term use, please adjust in the next way.

Remove the terminal cover and VR cap before adjustment, and attach the VR cap and terminal cover after adjustment.

- (1) For the output load, connect an actual load (within the output load range indicated on the name plate) or a simulated load with the same resistance value as the actual load.
- (2) Apply the auxiliary power supply (rated) and the input equivalent to 50% of the rated output value, and energize for 15 minutes.
- (3) Enter the lower limit of the rated output range and adjust with BIAS adjustment VR so that the output becomes the lower limit.  
Next, enter the upper limit of the rated output range and adjust the MAX adjustment VR so that the output reaches the upper limit.  
(The screwdriver for adjustment : Tip width of 1.8 to 2.3mm, Phillips-head screwdriver or flat-blade screwdriver)

## 10. Type composition

Single Phase Active Power Transducer

Type                      Specification code  
**WTT2-92A-12-①②③④⑤⑥**

1) Rated current, 1A

① Model		② Input		③ Rated voltage		④ Rated current		⑤ Output (Output load range)		⑥ Auxiliary supply	
B	Model B	1	0 to 100W	1	AC100V	1	AC1A	2	DC0 to 1V (200Ω or more)	F	AC80 to 264V
	A	-100 to 100W	2	AC105V			3	DC0 to 5V (600Ω or more)	DC80 to 264V		
			3	AC110V			4	DC0 to 10V (2kΩ or more)	AC/DC power supply		
			4	AC115V			5	DC1 to 5V (600Ω or more)	3	DC20 to 57V	
	1	0 to 100W	5	AC200V			6	DC-5 to 5V (600Ω or more)	Z	Other	
	2	0 to 150W	6	AC210V			7	DC-10 to 10V (2kΩ or more)			
	3	0 to 166.7W	7	AC220V			A	DC0 to 1mA (10kΩ or less)			
	4	0 to 200W					B	DC0 to 5mA (2kΩ or less)			
	A	-100 to 100W					C	DC0 to 10mA (1kΩ or less)			
	B	-150 to 150W					F	DC4 to 20mA (550Ω or less)			
	C	-166.7 to 166.7W					G	DC-1 to 1mA (10kΩ or less)			
	D	-200 to 200W			Z	Other					
	Z	Other	Z	Other	Z	Other					

2) Rated current, 5A

① Model		② Input		③ Rated voltage		④ Rated current		⑤ Output (Output load range)		⑥ Auxiliary supply	
B	Model B	1	0 to 500W	1	AC100V	2	AC5A	2	DC0 to 1V (200Ω or more)	F	AC80 to 264V
	A	-500 to 500W	2	AC105V			3	DC0 to 5V (600Ω or more)	DC80 to 264V		
			3	AC110V			4	DC0 to 10V (2kΩ or more)	AC/DC power supply		
			4	AC115V			5	DC1 to 5V (600Ω or more)	3	DC20 to 57V	
	1	0 to 500W	5	AC200V			6	DC-5 to 5V (600Ω or more)	Z	Other	
	2	0 to 750W	6	AC210V			7	DC-10 to 10V (2kΩ or more)			
	3	0 to 833.3W	7	AC220V			A	DC0 to 1mA (10kΩ or less)			
	4	0 to 1kW					B	DC0 to 5mA (2kΩ or less)			
	A	-500 to 500W					C	DC0 to 10mA (1kΩ or less)			
	B	-750 to 750W					F	DC4 to 20mA (550Ω or less)			
	C	-833.3 to 833.3W					G	DC-1 to 1mA (10kΩ or less)			
	D	-1 to 1kW			Z	Other					
	Z	Other	Z	Other	Z	Other					

## Single Phase Three Wire Active Power Transducer

Type                      Specification code  
**WTT2-92A-13-** ①②③④⑤⑥

## 1) Rated current, 1A

① Model	② Input		③ Rated voltage		④ Rated current		⑤ Output (Output load range)		⑥ Auxiliary supply		
B   Model B	1	0 to 100W	1	AC100V	1	AC1A	2	DC0 to 1V (200Ω or more)	F	AC80 to 264V DC80 to 264V AC/DC power supply	
	2	0 to 150W	2	AC105V			3	DC0 to 5V (600Ω or more)			
	3	0 to 166.7W	3	AC110V			4	DC0 to 10V (2kΩ or more)			
	4	0 to 200W	4	AC115V			5	DC1 to 5V (600Ω or more)			
	A	-100 to 100W	Phase voltage with neutral				6	DC-5 to 5V (600Ω or more)	3	DC20 to 57V	
	B	-150 to 150W						7	DC-10 to 10V (2kΩ or more)	Z	Other
	C	-166.7 to 166.7W						A	DC0 to 1mA (10kΩ or less)		
	D	-200 to 200W						B	DC0 to 5mA (2kΩ or less)		
	Z	Other	Z	Other	Z	Other	C	DC0 to 10mA (1kΩ or less)			
							F	DC4 to 20mA (550Ω or less)			
							G	DC-1 to 1mA (10kΩ or less)			
							Z	Other			

## 2) Rated current, 5A

① Model	② Input		③ Rated voltage		④ Rated current		⑤ Output (Output load range)		⑥ Auxiliary supply		
B   Model B	1	0 to 500W	1	AC100V	2	AC5A	2	DC0 to 1V (200Ω or more)	F	AC80 to 264V DC80 to 264V AC/DC power supply	
	2	0 to 750W	2	AC105V			3	DC0 to 5V (600Ω or more)			
	3	0 to 833.3W	3	AC110V			4	DC0 to 10V (2kΩ or more)			
	4	0 to 1kW	4	AC115V			5	DC1 to 5V (600Ω or more)			
	A	-500 to 500W	Phase voltage with neutral				6	DC-5 to 5V (600Ω or more)	3	DC20 to 57V	
	B	-750 to 750W						7	DC-10 to 10V (2kΩ or more)	Z	Other
	C	-833.3 to 833.3W						A	DC0 to 1mA (10kΩ or less)		
	D	-1 to 1kW						B	DC0 to 5mA (2kΩ or less)		
	Z	Other	Z	Other	Z	Other	C	DC0 to 10mA (1kΩ or less)			
							F	DC4 to 20mA (550Ω or less)			
							G	DC-1 to 1mA (10kΩ or less)			
							Z	Other			

## Three Phase Three Wire Active Power Transducer

Type Specification code  
**WTT2-92A-33-①②③④⑤⑥**

## 1) Rated current, 1A

① Model	② Input		③ Rated voltage		④ Rated current		⑤ Output (Output load range)		⑥ Auxiliary supply	
B   Model B	1	0 to 100W	1	AC100V	1	AC1A	2	DC0 to 1V (200Ω or more)	F	AC80 to 264V
	2	0 to 150W	2	AC105V			3	DC0 to 5V (600Ω or more)		DC80 to 264V
	3	0 to 166.7W	3	AC110V			4	DC0 to 10V (2kΩ or more)		AC/DC power supply
	4	0 to 200W	4	AC115V			5	DC1 to 5V (600Ω or more)	3	DC20 to 57V
	A	-100 to 100W					6	DC-5 to 5V (600Ω or more)	Z	Other
	B	-150 to 150W					7	DC-10 to 10V (2kΩ or more)		
	C	-166.7 to 166.7W					A	DC0 to 1mA (10kΩ or less)		
	D	-200 to 200W					B	DC0 to 5mA (2kΩ or less)		
	4	0 to 200W	5	AC200V			C	DC0 to 10mA (1kΩ or less)		
	5	0 to 300W	6	AC210V			F	DC4 to 20mA (550Ω or less)		
	6	0 to 333.3W	7	AC220V			G	DC-1 to 1mA (10kΩ or less)		
	7	0 to 400W					Z	Other		
	D	-200 to 200W								
	E	-300 to 300W								
	F	-333.3 to 333.3W								
	G	-400 to 400W								
	Z	Other	Z	Other	Z	Other				

## 2) Rated current, 5A

① Model	② Input		③ Rated voltage		④ Rated current		⑤ Output (Output load range)		⑥ Auxiliary supply	
B   Model B	1	0 to 500W	1	AC100V	2	AC5A	2	DC0 to 1V (200Ω or more)	F	AC80 to 264V
	2	0 to 750W	2	AC105V			3	DC0 to 5V (600Ω or more)		DC80 to 264V
	3	0 to 833.3W	3	AC110V			4	DC0 to 10V (2kΩ or more)		AC/DC power supply
	4	0 to 1kW	4	AC115V			5	DC1 to 5V (600Ω or more)	3	DC20 to 57V
	A	-500 to 500W					6	DC-5 to 5V (600Ω or more)	Z	Other
	B	-750 to 750W					7	DC-10 to 10V (2kΩ or more)		
	C	-833.3 to 833.3W					A	DC0 to 1mA (10kΩ or less)		
	D	-1 to 1kW					B	DC0 to 5mA (2kΩ or less)		
	4	0 to 1kW	5	AC200V			C	DC0 to 10mA (1kΩ or less)		
	5	0 to 1.5kW	6	AC210V			F	DC4 to 20mA (550Ω or less)		
	6	0 to 1.667kW	7	AC220V			G	DC-1 to 1mA (10kΩ or less)		
	7	0 to 2kW					Z	Other		
	D	-1 to 1kW								
	E	-1.5 to 1.5kW								
	F	-1.667 to 1.667kW								
	G	-2 to 2kW								
	Z	Other	Z	Other	Z	Other				



## Three Phase Four Wire Active Power Transducer

Type Specification code

**WTT2-92A-34-①②③④⑤⑥**

## 1) Rated current, 1A

① Model	② Input	③ Rated voltage	④ Rated current	⑤ Output (Output load range)	⑥ Auxiliary supply
B Model B	1 0 to 100W	1 AC100/ $\sqrt{3}$ V	1 AC1A	2 DC0 to 1V (200 $\Omega$ or more)	F AC80 to 264V DC80 to 264V AC/DC power supply
	2 0 to 150W	2 AC105/ $\sqrt{3}$ V		3 DC0 to 5V (600 $\Omega$ or more)	
	3 0 to 166.7W	3 AC110/ $\sqrt{3}$ V		4 DC0 to 10V (2k $\Omega$ or more)	3 DC20 to 57V
	4 0 to 200W	4 AC115/ $\sqrt{3}$ V		5 DC1 to 5V (600 $\Omega$ or more)	
	A -100 to 100W			6 DC-5 to 5V (600 $\Omega$ or more)	Z Other
	B -150 to 150W			7 DC-10 to 10V (2k $\Omega$ or more)	
	C -166.7 to 166.7W			A DC0 to 1mA (10k $\Omega$ or less)	
	D -200 to 200W			B DC0 to 5mA (2k $\Omega$ or less)	
	4 0 to 200W	5 AC200/ $\sqrt{3}$ V		C DC0 to 10mA (1k $\Omega$ or less)	
	5 0 to 300W	6 AC210/ $\sqrt{3}$ V		F DC4 to 20mA (550 $\Omega$ or less)	
	6 0 to 333.3W	7 AC220/ $\sqrt{3}$ V		G DC-1 to 1mA (10k $\Omega$ or less)	
	7 0 to 400W			Z Other	
	D -200 to 200W				
	E -300 to 300W				
	F -333.3 to 333.3W				
	G -400 to 400W				
	Z Other	Z Other	Z Other		

## 2) Rated current, 5A

① Model	② Input	③ Rated voltage	④ Rated current	⑤ Output (Output load range)	⑥ Auxiliary supply
B Model B	1 0 to 500W	1 AC100/ $\sqrt{3}$ V	2 AC5A	2 DC0 to 1V (200 $\Omega$ or more)	F AC80 to 264V DC80 to 264V AC/DC power supply
	2 0 to 750W	2 AC105/ $\sqrt{3}$ V		3 DC0 to 5V (600 $\Omega$ or more)	
	3 0 to 833.3W	3 AC110/ $\sqrt{3}$ V		4 DC0 to 10V (2k $\Omega$ or more)	3 DC20 to 57V
	4 0 to 1kW	4 AC115/ $\sqrt{3}$ V		5 DC1 to 5V (600 $\Omega$ or more)	
	A -500 to 500W			6 DC-5 to 5V (600 $\Omega$ or more)	Z Other
	B -750 to 750W			7 DC-10 to 10V (2k $\Omega$ or more)	
	C -833.3 to 833.3W			A DC0 to 1mA (10k $\Omega$ or less)	
	D -1 to 1kW			B DC0 to 5mA (2k $\Omega$ or less)	
	4 0 to 1kW	5 AC200/ $\sqrt{3}$ V		C DC0 to 10mA (1k $\Omega$ or less)	
	5 0 to 1.5kW	6 AC210/ $\sqrt{3}$ V		F DC4 to 20mA (550 $\Omega$ or less)	
	6 0 to 1.667kW	7 AC220/ $\sqrt{3}$ V		G DC-1 to 1mA (10k $\Omega$ or less)	
	7 0 to 2kW			Z Other	
	D -1 to 1kW				
	E -1.5 to 1.5kW				
	F -1.667 to 1.667kW				
	G -2 to 2kW				
	Z Other	Z Other	Z Other		

** DAIICHI ELECTRONICS CO., LTD.**

Tokyo Office : 11-13, Hitotsuya 1-chome, Adachi-ku, Tokyo, 121-8639, JAPAN.  
TEL : +81-3-3885-2411 , FAX : +81-3-3858-3966

Kyoto Office : 1-19, Ichinobe-Nishikawahara, Jyoyou-shi, Kyoto, 610-0114, JAPAN.  
TEL : +81-774-55-1391 , FAX : +81-774-54-1353

Revision A, DATE : October 31, 2022