

**UCP**  
Cylindrical bore (with set screws)  
*d* 12 ~ (45) mm

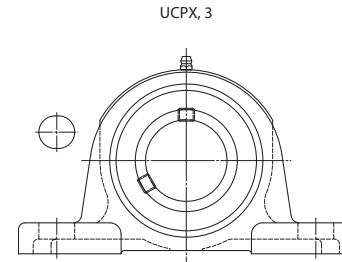

With Pressed Steel Cover

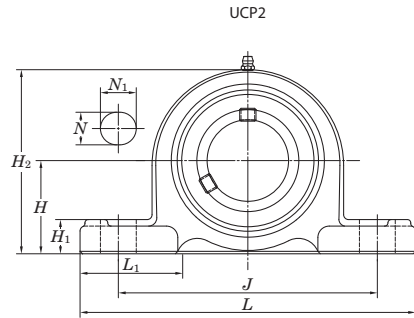
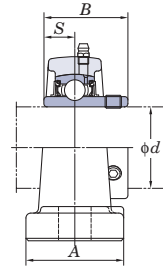
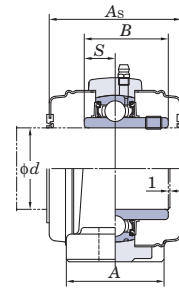

With Cast Iron Cover

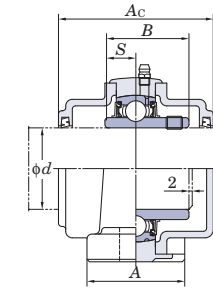

Variations of tolerance of distance from mounting bottom to center of spherical bore ( $\Delta H_{2c}$ )

| Housing No. |           | $\Delta H_{2c}$ |
|-------------|-----------|-----------------|
| P203~P210   | PX05~PX10 | +0.15           |
| P211~P218   | PX11~PX18 | +0.2            |
| P219~P226   | PX19~PX26 | +0.3            |

Forms and dimensions of  $H_{2c}$  of P204JE3 and P205JE3 (housing with cast iron cover) are shown below.

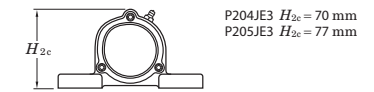

| Shaft Dia.<br>mm<br><i>d</i> | inch  | Dimensions<br>inch<br>mm |          |          |          |          |                       |                       |                       |                       |          |          | Bolt<br>Size<br>inch<br>mm | Standard  |             |             | Mass<br>kg | Basic<br>Load Ratings<br>kN |                         | Factor<br><i>f</i> <sub>0</sub> | With Pressed Steel Cover |          |                         |            | With Cast Iron Cover |          |           |    |         |      |   |   |           |           |          |         |      |   |   |   |   |   |
|------------------------------|-------|--------------------------|----------|----------|----------|----------|-----------------------|-----------------------|-----------------------|-----------------------|----------|----------|----------------------------|-----------|-------------|-------------|------------|-----------------------------|-------------------------|---------------------------------|--------------------------|----------|-------------------------|------------|----------------------|----------|-----------|----|---------|------|---|---|-----------|-----------|----------|---------|------|---|---|---|---|---|
|                              |       | <i>H</i>                 | <i>L</i> | <i>A</i> | <i>J</i> | <i>N</i> | <i>N</i> <sub>1</sub> | <i>H</i> <sub>1</sub> | <i>H</i> <sub>2</sub> | <i>L</i> <sub>1</sub> | <i>B</i> | <i>S</i> |                            | Unit No.  | Housing No. | Bearing No. |            | Unit No.                    | Dimension<br>mm<br>inch |                                 | Mass<br>kg               | Unit No. | Dimension<br>mm<br>inch | Mass<br>kg |                      |          |           |    |         |      |   |   |           |           |          |         |      |   |   |   |   |   |
| 12                           | 1/2   | 3 1/16                   | 5        | 1 1/2    | 3 3/4    | 1/2      | 23/32                 | 5/8                   | 2 3/8                 | 1 13/32               | 1.220    | 0.500    | 3/8                        | UCP201    | P203        | UC201       | 0.63       | 12.8                        | 6.65                    | 13.2                            | UCP201C                  | UCP201CD | 45                      | 1 25/32    | 0.63                 | -        | -         | -  | -       | -    | - | - | -         |           |          |         |      |   |   |   |   |   |
|                              |       |                          |          |          |          |          |                       |                       |                       |                       |          |          |                            |           |             |             |            |                             |                         |                                 |                          |          |                         |            |                      |          |           |    |         |      |   |   |           | UCP201-8  | UC201-8  | -       | -    | - | - | - | - | - |
|                              |       |                          |          |          |          |          |                       |                       |                       |                       |          |          |                            |           |             |             |            |                             |                         |                                 |                          |          |                         |            |                      |          |           |    |         |      |   |   |           | UCP202    | UC202    | -       | -    | - | - | - | - | - |
|                              |       |                          |          |          |          |          |                       |                       |                       |                       |          |          |                            |           |             |             |            |                             |                         |                                 |                          |          |                         |            |                      |          |           |    |         |      |   |   |           | UCP202-10 | UC202-10 | -       | -    | - | - | - | - | - |
| 15                           | 5/8   | 30.2                     | 127      | 38       | 95       | 13       | 18                    | 16                    | 60                    | 36                    | 31       | 12.7     | M10                        | UCP202    | P203        | UC202       | 0.61       | 12.8                        | 6.65                    | 13.2                            | UCP202C                  | UCP202CD | 45                      | 1 25/32    | 0.61                 | -        | -         | -  | -       | -    | - | - |           |           |          |         |      |   |   |   |   |   |
|                              |       |                          |          |          |          |          |                       |                       |                       |                       |          |          |                            |           |             |             |            |                             |                         |                                 |                          |          |                         |            |                      |          |           |    |         |      |   |   | UCP202-10 | UC202-10  | -        | -       | -    | - | - | - | - |   |
|                              |       |                          |          |          |          |          |                       |                       |                       |                       |          |          |                            |           |             |             |            |                             |                         |                                 |                          |          |                         |            |                      |          |           |    |         |      |   |   | UCP203    | UC203     | -        | -       | -    | - | - | - | - |   |
|                              |       |                          |          |          |          |          |                       |                       |                       |                       |          |          |                            |           |             |             |            |                             |                         |                                 |                          |          |                         |            |                      |          |           |    |         |      |   |   | UCP203C   | UCP203CD  | 45       | 1 25/32 | 0.60 | - | - | - | - |   |
| 17                           | 3/4   | 33.3                     | 127      | 38       | 95       | 13       | 18                    | 16                    | 65                    | 36                    | 31       | 12.7     | M10                        | UCP204-12 | P204        | UC204-12    | 0.66       | 12.8                        | 6.65                    | 13.2                            | UCP204C                  | UCP204CD | 45                      | 1 25/32    | 0.66                 | UCP204FC | UCP204FCD | 62 | 2 7/16  | 0.96 | - | - |           |           |          |         |      |   |   |   |   |   |
|                              |       |                          |          |          |          |          |                       |                       |                       |                       |          |          |                            |           |             |             |            |                             |                         |                                 |                          |          |                         |            |                      |          |           |    |         |      |   |   | UCP204    | UC204     | -        | -       | -    | - | - | - | - |   |
|                              |       |                          |          |          |          |          |                       |                       |                       |                       |          |          |                            |           |             |             |            |                             |                         |                                 |                          |          |                         |            |                      |          |           |    |         |      |   |   | UCP205-14 | UC205-14  | -        | -       | -    | - | - | - | - |   |
|                              |       |                          |          |          |          |          |                       |                       |                       |                       |          |          |                            |           |             |             |            |                             |                         |                                 |                          |          |                         |            |                      |          |           |    |         |      |   |   | UCP205-15 | UC205-15  | -        | -       | -    | - | - | - | - |   |
| 20                           | 7/8   | 36.5                     | 140      | 38       | 105      | 13       | 18                    | 16                    | 70                    | 38                    | 34.1     | 14.3     | M10                        | UCP205    | P205        | UC205       | 0.80       | 14.0                        | 7.85                    | 13.9                            | UCP205C                  | UCP205CD | 49                      | 1 15/16    | 0.80                 | UCP205FC | UCP205FCD | 66 | 2 19/32 | 1.2  | - | - |           |           |          |         |      |   |   |   |   |   |
|                              |       |                          |          |          |          |          |                       |                       |                       |                       |          |          |                            |           |             |             |            |                             |                         |                                 |                          |          |                         |            |                      |          |           |    |         |      |   |   | UCP205-16 | UC205-16  | -        | -       | -    | - | - | - | - |   |
|                              |       |                          |          |          |          |          |                       |                       |                       |                       |          |          |                            |           |             |             |            |                             |                         |                                 |                          |          |                         |            |                      |          |           |    |         |      |   |   | UCP205    | UC205     | -        | -       | -    | - | - | - | - |   |
|                              |       |                          |          |          |          |          |                       |                       |                       |                       |          |          |                            |           |             |             |            |                             |                         |                                 |                          |          |                         |            |                      |          |           |    |         |      |   |   | UCP205C   | UCP205CD  | 49       | 1 15/16 | 0.80 | - | - | - | - |   |
| 25                           | 1     | 44.4                     | 159      | 51       | 119      | 17       | 25                    | 16                    | 86                    | 47                    | 38.1     | 15.9     | M14                        | UCPX05    | PX05        | UCX05       | 1.5        | 19.5                        | 11.3                    | 13.9                            | UCPX05C                  | UCPX05CD | 53                      | 2 3/32     | 1.5                  | -        | -         | -  | -       | -    | - | - |           |           |          |         |      |   |   |   |   |   |
|                              |       |                          |          |          |          |          |                       |                       |                       |                       |          |          |                            |           |             |             |            |                             |                         |                                 |                          |          |                         |            |                      |          |           |    |         |      |   |   | UCPX05-16 | UCX05-16  | -        | -       | -    | - | - | - | - |   |
|                              |       |                          |          |          |          |          |                       |                       |                       |                       |          |          |                            |           |             |             |            |                             |                         |                                 |                          |          |                         |            |                      |          |           |    |         |      |   |   | UCP305    | UC305     | -        | -       | -    | - | - | - | - |   |
|                              |       |                          |          |          |          |          |                       |                       |                       |                       |          |          |                            |           |             |             |            |                             |                         |                                 |                          |          |                         |            |                      |          |           |    |         |      |   |   | UCP305-16 | UC305-16  | -        | -       | -    | - | - | - | - |   |
| 30                           | 1 1/8 | 42.9                     | 165      | 48       | 121      | 17       | 21                    | 17                    | 84                    | 48                    | 38.1     | 15.9     | M14                        | UCP206-18 | P206        | UC206-18    | 1.3        | 19.5                        | 11.3                    | 13.9                            | UCP206C                  | UCP206CD | 53                      | 2 3/32     | 1.3                  | UCP206FC | UCP206FCD | 70 | 2 3/4   | 1.8  | - | - |           |           |          |         |      |   |   |   |   |   |
|                              |       |                          |          |          |          |          |                       |                       |                       |                       |          |          |                            |           |             |             |            |                             |                         |                                 |                          |          |                         |            |                      |          |           |    |         |      |   |   | UCP206    | UC206     | -        | -       | -    | - | - | - | - |   |
|                              |       |                          |          |          |          |          |                       |                       |                       |                       |          |          |                            |           |             |             |            |                             |                         |                                 |                          |          |                         |            |                      |          |           |    |         |      |   |   | UCP206-19 | UC206-19  | -        | -       | -    | - | - | - | - |   |
|                              |       |                          |          |          |          |          |                       |                       |                       |                       |          |          |                            |           |             |             |            |                             |                         |                                 |                          |          |                         |            |                      |          |           |    |         |      |   |   | UCP206-20 | UC206-20  | -        | -       | -    | - | - | - | - |   |
| 35                           | 1 3/8 | 47.6                     | 175      | 57       | 127      | 17       | 25                    | 17                    | 93                    | 55                    | 42.9     | 17.5     | M14                        | UCPX06    | PX06        | UCX06       | 2.1        | 25.7                        | 15.4                    | 13.9                            | UCPX06C                  | UCPX06CD | 60                      | 2 3/8      | 2.1                  | -        | -         | -  | -       | -    | - | - |           |           |          |         |      |   |   |   |   |   |
|                              |       |                          |          |          |          |          |                       |                       |                       |                       |          |          |                            |           |             |             |            |                             |                         |                                 |                          |          |                         |            |                      |          |           |    |         |      |   |   | UCPX06-19 | UCX06-19  | -        | -       | -    | - | - | - | - |   |
|                              |       |                          |          |          |          |          |                       |                       |                       |                       |          |          |                            |           |             |             |            |                             |                         |                                 |                          |          |                         |            |                      |          |           |    |         |      |   |   | UCPX06-20 | UCX06-20  | -        | -       | -    | - | - | - | - |   |
|                              |       |                          |          |          |          |          |                       |                       |                       |                       |          |          |                            |           |             |             |            |                             |                         |                                 |                          |          |                         |            |                      |          |           |    |         |      |   |   | UCP306    | UC306     | -        | -       | -    | - | - | - | - |   |
| 40                           | 1 1/2 | 49.2                     | 184      | 54       | 137      | 17       | 21                    | 18                    | 98                    | 53                    | 49.2     | 19       | M14                        | UCP207-20 | P207        | UC207-20    | 1.6        | 25.7                        | 15.4                    | 13.9                            | UCP207C                  | UCP207CD | 60                      | 2 3/8      | 1.6                  | UCP207FC | UCP207FCD | 78 | 3 1/16  | 2.3  | - | - |           |           |          |         |      |   |   |   |   |   |
|                              |       |                          |          |          |          |          |                       |                       |                       |                       |          |          |                            |           |             |             |            |                             |                         |                                 |                          |          |                         |            |                      |          |           |    |         |      |   |   | UCP207-21 | UC207-21  | -        | -       | -    | - | - | - | - |   |
|                              |       |                          |          |          |          |          |                       |                       |                       |                       |          |          |                            |           |             |             |            |                             |                         |                                 |                          |          |                         |            |                      |          |           |    |         |      |   |   | UCP207-22 | UC207-22  | -        | -       | -    | - | - | - | - |   |
|                              |       |                          |          |          |          |          |                       |                       |                       |                       |          |          |                            |           |             |             |            |                             |                         |                                 |                          |          |                         |            |                      |          |           |    |         |      |   |   | UCP207    | UC207     | -        | -       | -    | - | - | - | - |   |
| 45                           | 1 3/4 | 54                       | 190      | 54       | 146      | 17       | 21                    | 20                    | 106                   | 55                    | 49.2     | 19       | M14                        | UCPX07-22 | PX07        | UCX07-22    | 2.7        | 29.1                        | 17.8                    | 14.0                            | UCPX07C                  | UCPX07CD | 69                      | 2 23/32    | 2.7                  | -        | -         | -  | -       | -    | - | - |           |           |          |         |      |   |   |   |   |   |
|                              |       |                          |          |          |          |          |                       |                       |                       |                       |          |          |                            |           |             |             |            |                             |                         |                                 |                          |          |                         |            |                      |          |           |    |         |      |   |   | UCPX07    | UCX07     | -        | -       | -    | - | - | - | - |   |
|                              |       |                          |          |          |          |          |                       |                       |                       |                       |          |          |                            |           |             |             |            |                             |                         |                                 |                          |          |                         |            |                      |          |           |    |         |      |   |   | UCPX07-23 | UCX07-23  | -        | -       | -    | - | - | - | - |   |
|                              |       |                          |          |          |          |          |                       |                       |                       |                       |          |          |                            |           |             |             |            |                             |                         |                                 |                          |          |                         |            |                      |          |           |    |         |      |   |   | UCP307    | UC307     | -        | -       | -    | - | - | - | - |   |

Remarks 1. In Part No. of unit and units with covers, fitting codes follow bore diameter numbers. (See Table 10.5 in P.62.)  
2. Part No. of applicable grease fittings are shown below.  
A-1/4-28UNF ..... 201~210, X05~X09, 305~308  
A-R1/8 ..... 211~218, X10~X20, 309~328

3. As for the triple seal type product (from 201 to 205 are the double seal type products), suffix code L3 (or L2) follows the Part No. of unit or bearing. (Example of Part No.: UCP206JL3, UC206L3)  
4. For the dimensions and forms of applicable bearings, see the dimensional tables of ball bearing for unit.  
5. Representative examples of the forms of housing are indicated.  
6. Housings of nodular graphite cast iron are also available.