

SECTIONAL DRAWING		No.	No. A-06519-3
TYPE Sewage Submersible Vortex Pump (Automatic)		MODEL	40UA2.25 -51/61

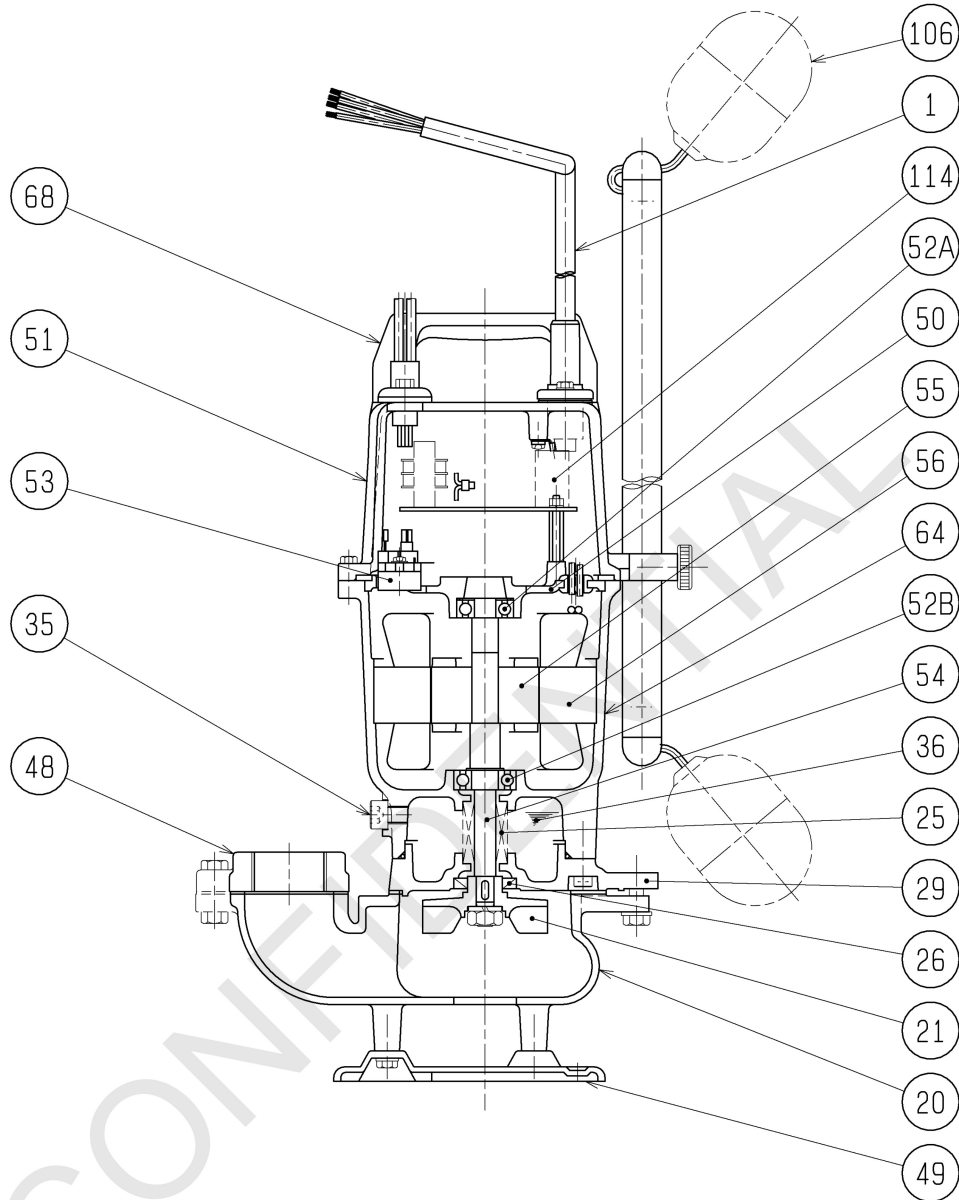

REQ. SPECIFICATION	

No.	DESCRIPTION	QTY	MATERIAL / NOTE	No.	DESCRIPTION	QTY	MATERIAL / NOTE
1	Cable	1	PVC Sheath	52A	Upper Bearing	1	6201ZZC3
20	Pump Casing	1	Gray Iron Casting	52B	Lower Bearing	1	6202ZZC3
21	Impeller	1	Gray Iron Casting	53	Motor Protector	1	
25	Mechanical Seal	1	D-12RC	54	Shaft	1	Stainless Steel 403
26	Oil Seal	1	VC20356	55	Rotor	1	
29	Oil Casing	1	Gray Iron Casting	56	Stator	1	
35	Oil Plug	1	Stainless Steel 304	64	Motor Frame	1	Gray Iron Casting
36	Lubricant		Turbine Oil (ISO VG32)	68	Handle	1	Plastic
48	Screwed Flange	1	Gray Iron Casting	106	Float	2	Plastic
49	Bottom Plate	1	Nylon	114	Relay Unit	1	
50	Motor Bracket	1	Gray Iron Casting				
51	Head Cover	1	Gray Iron Casting				