

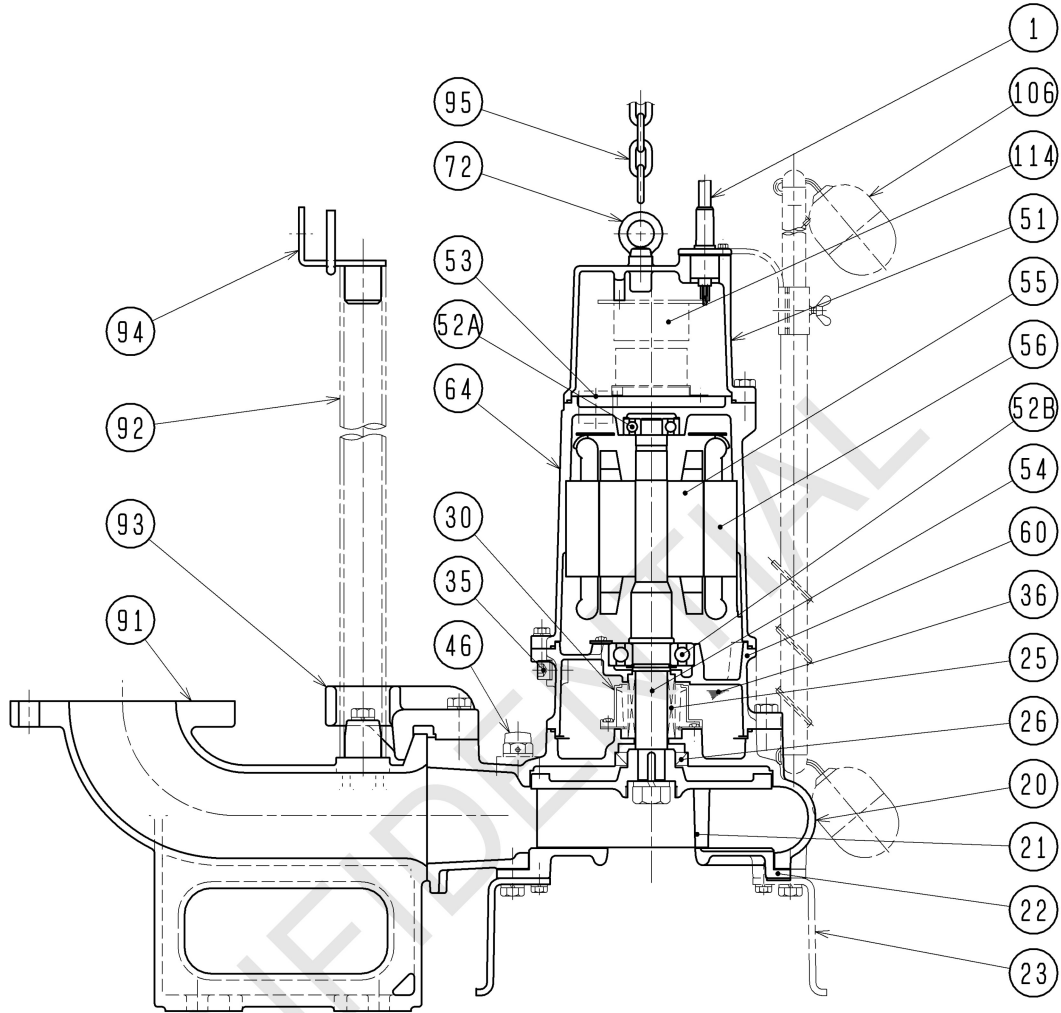

<b>SECTIONAL DRAWING</b>		No.	No.	A-08537-3
TYPE	Sewage Submersible Channel Impeller Pump (Automatic)	MODEL	TOS100BA42.2 -51/61 TOS100BA43.7 -51/61	



	2.2kW	3.7kW
※1	H-30A	H-35A
※2	TC456812	TC507212
※3	6307ZZC3	6309ZZC3

※4 the wetted part

REQ. SPECIFICATION		

No.	DESCRIPTION	QTY	MATERIAL / NOTE	No.	DESCRIPTION	QTY	MATERIAL / NOTE
1	Cable	1	PVC Sheath	54	Shaft	1	Stainless Steel 420J2(※4)
20	Pump Casing	1	Gray Iron Casting	55	Rotor	1	
21	Impeller	1	Gray Iron Casting	56	Stator	1	
22	Suction Cover	1	Gray Iron Casting	60	Bearing Housing	1	Gray Iron Casting
23	Stand	3	Steel Plate	64	Motor Frame	1	Gray Iron Casting
25	Mechanical Seal	1	※1	72	Eye Bolt	2	Stainless Steel 304
26	Oil Seal	1	※2	91	Duck Foot Bend	1	Gray Iron Casting
30	Oil Lifter	1	Plastic	92	Guide Pipe	2	Galvanized Steel Pipe (Option)
35	Oil Plug	1	Stainless Steel 304	93	Guide Hook	1	Ductile Iron Casting
36	Lubricant		Turbine Oil (ISO VG32)	94	Guide Support	1	Stainless Steel 304
46	Air Release Valve	1	Nylon	95	Chain	1	Structure Steel, 5m
51	Head Cover	1	Gray Iron Casting	106	Float	2	Plastic
52A	Upper Bearing	1	6304ZZC3	114	Relay Unit	1	
52B	Lower Bearing	1	※3				
53	Motor Protector	1					