

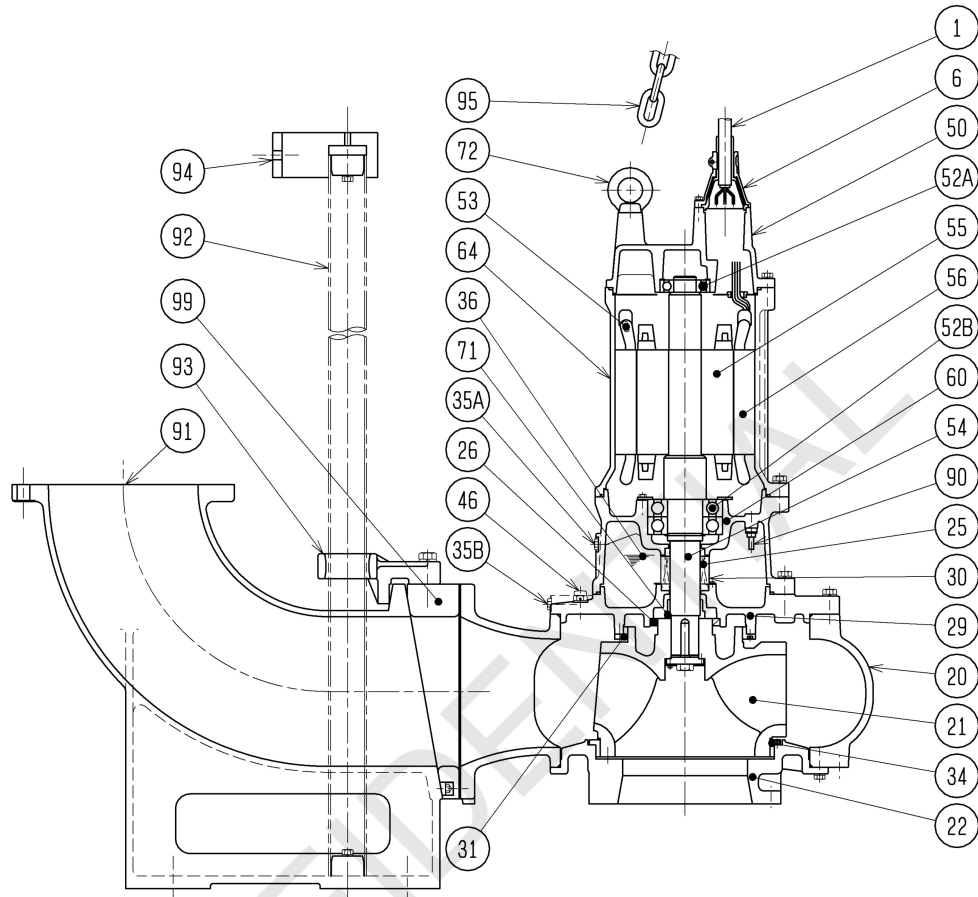

SECTIONAL DRAWING		No.	No.	A-19356-1
TYPE	Sewage Submersible Channel Impeller Pump	MODEL	T0300B622 -54/64	



REQ. SPECIFICATION

No.	DESCRIPTION	QTY	MATERIAL / NOTE	No.	DESCRIPTION	QTY	MATERIAL / NOTE
1	Cable	2	Chloroprene Sheath (For the Power)	52B	Lower Bearing	1	6314ZZD2C3
		1	PVC Sheath (For the Control)	53	Motor Protector	3	
6	Stuffing Box	2	Gray Iron Casting	54	Shaft	1	Stainless Steel 420J2
20	Pump Casing	1	Gray Iron Casting	55	Rotor	1	
21	Impeller	1	Gray Iron Casting	56	Stator	1	
22	Suction Cover	1	Gray Iron Casting	60	Bearing Housing	1	Gray Iron Casting
25	Mechanical Seal	1	H-60	64	Motor Frame	1	Gray Iron Casting
26	Oil Seal	1	TC11014014	71	Shaft Sleeve	1	Stainless Steel 304
29	Oil Casing	1	Gray Iron Casting	72	Eye Bolt	2	Structure Steel
30	Oil Lifter	1	Steel Plate	90	Leakage Sensor (Electrode)	1	Stainless Steel
31	Wear Ring	1	Gray Iron Casting	91	Duck Foot Bend	1	Gray Iron Casting
34	Mouth Ring	1	Gray Iron Casting	92	Guide Pipe	2	Galvanized Steel Pipe (Option)
35A	Oil Plug	2	Stainless Steel 304	93	Guide Hook	1	Ductile Iron Casting
35B	Oil Plug	1	Stainless Steel 304	94	Guide Support	1	Structure Steel
36	Lubricant		Turbine Oil (ISO VG32)	95	Chain	1	Structure Steel, 5m
46	Air Release Valve	1	Nylon	99	Fitting Flange	1	Gray Iron Casting
50	Motor Bracket	1	Gray Iron Casting				
52A	Upper Bearing	1	63097ZC3				