

SECTION 8

Motor Information for Coagulation Tank Mixer

00GNB06AM101



BOUSTEAD SALCON WATER SOLUTIONS PTE LTD

Motor Data sheets

1. Name of motor	-	COAGULATION TANK MIXER MOTOR
2. Manufacturer	-	TECO
3. Country of origin	-	MALAYSIA
4. Type/machine code	-	AEUB
5. Applied standard (characteristics)	-	IEC 60034-1
6. Ratings		
(1) Rated output	kW	0.75
(2) Service factor	-	1
(3) Number of pole	-	4
(4) Rated speed	min ⁻¹	1500
(5) Rated voltage	V	380
(6) Number of phases	-	3
(7) Rated frequency	Hz	50
(8) Insulation class	-	CLASS F
(9) Temperature rise	-	CLASS B/ 80°C
(10) Rated duty	-	S1
7. Service Conditions		
(1) Starting method	-	DOL
(2) Direction of rotation (viewed from DE)	-	CW
(3) Reverse rotation (Yes / No)	-	NO
(4) Location (Indoor / Outdoor)	-	OUTDOOR
(5) Enclosure IP rating		
(a) Motor frame	-	IP55
(b) Terminal boxes	-	IP55
(6) Installation (Horizontal / Vertical)	-	VERTICAL
(7) Design ambient temperature	°C	-14~40
(8) Explosion proof (Required / Not required)	-	NO
(9) Noise level (at full-load condition)	dB (A)	46
8. Characteristics		
(1) Current		
(a) Normal current	A	1.98
(b) No-load current	A	1.4
(c) Starting current	A	12.8

(2) Torque		
(a) Starting torque	%	370
(b) Maximum torque	%	370
(3) Slip at rated output		
(4) Efficiencies		
(a) At 100% load	%	81.5
(b) At 75% load	%	81.0
(c) At 50% load	%	77.5
(d) At 25% load	%	
(5) Power factor		
(a) At rated load	%	70.5
(b) At starting load	%	60
(6) GD2 coupled with driven equipment	kg-m ²	0.013
(7) Starting time with driven equipment	s	1
(8) Consecutive number of starts		
(a) From cold condition per hour	-	3
(b) From hot condition per hour	-	2
(c) Minimum time between 2 starts (running state)	min	
(d) Minimum time between 2 starts (stop state)	min	
(9) Allowable locked-rotor time		
(a) At cold condition	s	
(b) At hot condition	s	
9. Constructions		
(1) Stator winding connection (Wye / Delta)	-	DELTA
(2) Type of bearing (DE / NDE)	-	6204ZZ/6204ZZ
(3) Lubricants		
(a) Recommended lubricant and brand name	-	LI-BASE GREASE MULTEMP SRL
(b) Pouring method	-	
(c) Quantity of lubricant for initial filling	-	
(d) Recommended interval for recharging	-	20,000 OPERATING HOURS
(e) Recharging quantity	-	
(f) Location of pouring	-	
(indicated in the outline drawing)		
(4) Bearing cooling water requirement (if required)		NOT REQUIRED
(a) Quantity	m ³ /h	
(b) Inlet water temperature	°C	
(c) Required cooling water pressure	kPa	
(d) Type of cooling water	-	

(5) Water to air heat exchanger (if applied)		NOT APPLIED
(a) Quantity of cooling water	m ³ /h	
(b) Inlet water temperature	°C	
(c) Required cooling water pressure	kPa	
(d) Type of cooling water	-	
(6) Space heater (AC 220V 1 phase)	W	NOT APPLICABLE
(7) Weight	kg	18
10. Attached document numbers		
(1) Motor outline drawing	-	SEE PAGE 57
(2) Terminal box drawings		
(a) For main power	-	
(b) For instruments	-	
(c) For space heater	-	
(3) Current transformers (for MV motors only)		
(a) Characteristics curves	-	
(b) Outline drawing	-	
(4) Efficiency curves	-	
(5) Thermal capability curves		
(a) At cold condition	-	
(b) At hot condition	-	
(6) Starting and speed torque characteristics at 80%, 90% and 100% voltage	-	

TECO	OUTLINE DIMENSIONS	
DATE 6/20/2017	3-PHASE INDUCTION MOTOR	

MODEL	OUTPUT	POLE	TIME RATING	VOLTAGE	Hz	SYN. SPEED R.P.M.
	HP			V		
AEUB	1	4	Continuous Rating	380	50	1500

TOTALLY ENCLOSED FAN-COOLED VERTICAL TYPE. SQUIRREL-CAGE ROTOR

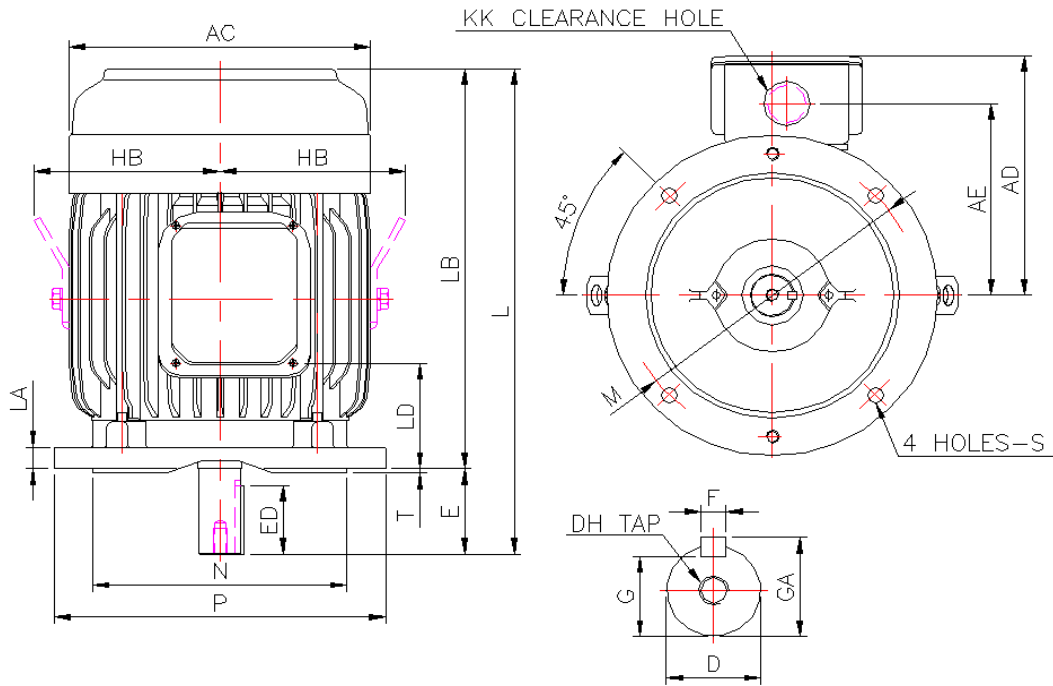

DIMENSIONS IN MM

FRAME NO.	AC	AD	AE	D	DH	E	ED	EE	F	G	
80	177	159	122	19j6	M6×12	40	25	---	6	15.5	
GA	HB	KK	L	LA	LB	LD	LR	M	N	P	S
21.5	---	20	282	12	242	55	---	165	130	200	12
T	D. E. BEARING	N. D. E. BEARING	APPROX. WEIGHT KGS		SOUND PRESSURE LEVEL dBA/1M						
3.5	6204ZZ	6204ZZ	18		46						

NOTE: 1. F Class Insulation, S.F.1.0
2. Direct Coupling, Belt Drive

10.1 MOTOR OUTLINE DRAWING

PRELIMINARY
DATE: 6/20/2017

APPD.	tIm	6/20/2017	TECO Electric & Machinery Co., Ltd.	DWG NO.
CHKD.	tIm	6/20/2017		
DWN.	tIm	6/20/2017		

All information published on this website is provided as is without any representation or warranty or any kind either express or implied including but not limited to implied warranties for merchantability, fitness for a particular purpose or non-infringement. Any documents may include technical inaccuracies or typographical errors. Teco reserves the right to change any information from time to time to any information provide here.