

# 4m<sup>3</sup> Electric Sludge Cake Hopper

## Instruction Manual

CONFIDENTIAL

SHANGHAI LING RAN WATER TREATMENT ENGINEERING CO

## 1. Summary of equipment

This mud bucket is a necessary auxiliary facility for the centrifugal dehydrator equipment in the wastewater treatment system of the power plant, and is also suitable for the wastewater treatment in other industries. The function of the sludge bucket is to send the mud cake separated by the concentrated sludge into the mud bucket and store all the mud cakes.

## 2. An overview of the institutions

2.1 A centrifugal dehydrator is used to separate the mud cake into the storage tank, and after quantitative, it is contracted by the piston push rod of the electric opening mechanism, so that the left and right grab bucket is opened at the same time, and the mud cake is discharged.

2.2 Electric bucket opening mechanism of 0.8kw, the motor through two gear reducer, warp rod drive nut, nut is installed on the piston rod on the axial displacement of the rotary motion into linear motion, connected with the pin to grab, grab the open or closed.

## 3. The main performance parameters

Mud bucket capacity: 4m<sup>3</sup>

Speed of fighting: 0.055rad/s

Maximum opening of mud bucket: 92.5°

The power of the conical rotor motor: 0.8kw

Speed: 1380r/min

Voltage: 380V

Frequency: 50Hz

Mud bucket weight: 2600kg

Outer size of mud bucket (mm): 2280×1935×3000

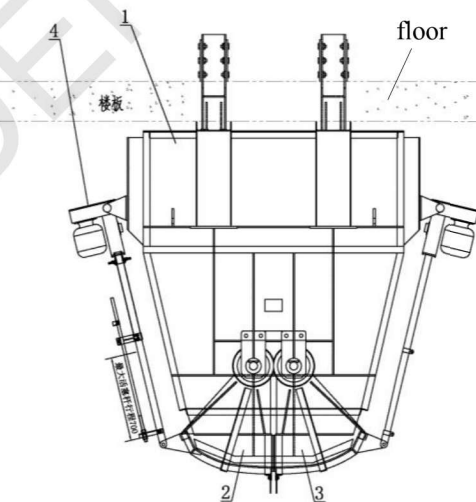

**Figure 1 Type ND-4 mud bucket device**

1. Mud tank 2. Left grab 3. Right grab 4. Electric hopper mechanism

## 4. Site installation

4.1. Lift the ND4-01# mud bucket body and support the ear through the reserved hole.

4.2. ND4-02# mud bucket connecting plate 1, ND4-03# mud bucket connecting plate 2 and ND4-01# mud bucket body are fixed with bolts.

4.3. Adjust the lifting height to make the bottom of the ND4-02# hopper connecting plate 1