

**Induction motor for Long Travel Drive**

Item	Terms	Description
1	Type	TK-FXV
2	FRAME	VA-132M-4/FB-15E
3	Rating	380V, 50Hz, 7.5kW, 4 poles
4	CONNECTION	$\Delta$
5	Rating speed (rpm)	1445 rpm
6	Current (A)	15.2A @50Hz, 14.2A @5Hz
7	Efficiency ( $\eta$ )	full load 100%=85% $\eta$ , 3/4 load % $\eta$ = 84.63%
8	Power factor $\cos\Phi$	0.91
9	Service Duty	Continuous Rating (S1)
10	Stator winding	Copper, Insulation class F
11	Enclosure	IP55
12	Cooling method	IC411
13	Max. AMB	40°C
14	Standard	IEC60034-1
15	MAKE	Sumitomo Heavy Industries, Ltd.

Construction drawing of motor (for direct coupling with Cyclo drive)

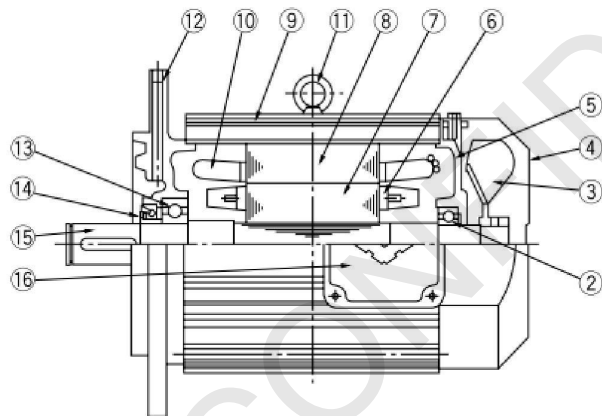

Fig.29 Example of construction of 80—112M frame

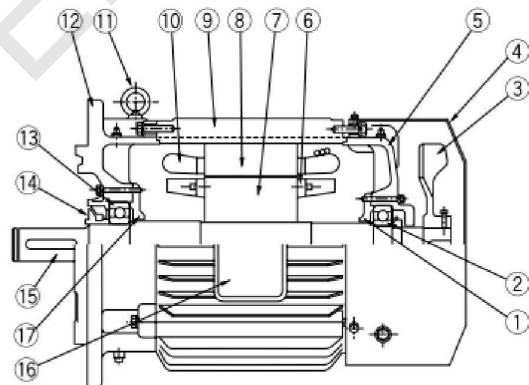

Fig.30 Example of construction of frame size 180 or above

Table 22 Main parts of motor

No.	Part name	No.	Part name	No.	Part name
1	Bearing cover	7	Rotor core	13	Motor shaft bearing A
2	Motor shaft bearing B	8	Stationary core	14	Oil slinger (Oil seal)
3	Fan	9	Stator frame	15	Motor shaft
4	Fan cover	10	Stator windings	16	Conduit box
5	End bracket	11	Eyebolt	17	Bearing cover
6	Rotor conductor short circuit ring	12	Cyclo flange bracket		

## 三合一减速机参数

## Datasheet of long travel gearbox motor

LHYM10-4D175-M-AVY2-B-102	参数 Data	
电机电压、频率 Motor voltage, frequency	380V/50Hz	
额定电流值(频率50Hz) Rated current at 50Hz	15.2A	
额定输出转速(频率50Hz) Rated speed at 50Hz	1445rpm	
接线盒出线口数量和尺寸 Terminal box cable inlets	2-M32x1.5;	
	2-M20x1.5;	
	1-M12;	
制动器电压 Brake voltage	220V	
制动器电流值 Brake current	1.1A	
制动器功率 Brake power	125W	
轴承型号 Bearing type	6309ZZ	数量1个 Qty. =1 pcs
	6307ZZ	数量1个 Qty. =1 pcs