

MOTOR DATASHEET

EQUIPMENT NAME: ACID METERING PUMP A/B

EQUIPMENT TAG NO.: 00LDN90/95 AP010

1. Name of motor	-	MOTOR FOR ACID METERING PUMP
2. Manufacturer	-	TECO
3. Country of origin	-	MALAYSIA
4. Type/machine code	-	SQUIRREL CAGE INDUCTION MOTOR AESU2S
5. Applied standard (characteristics)	-	IEC 60034-1
6. Ratings		
(1) Rated output	Kw	0.75
(2) Service factor	-	1.0
(3) Number of pole	-	2
(4) Rated speed	min ⁻¹	2850
(5) Rated voltage	V	380
(6) Number of phases	-	3
(7) Rated frequency	Hz	50
(8) Insulation class	-	CLASS F
(9) Temperature rise	-	CLASS B
(10) Rated duty	-	S1
7. Service Conditions		
(1) Starting method	-	DOL
(2) Direction of rotation (viewed from DE)	-	BI-DIRECTION
(3) Reverse rotation (Yes / No)	-	YES
(4) Location (Indoor / Outdoor)	-	OUTDOOR
(5) Enclosure IP rating	-	
(a) Motor frame		(a) IP 55

MOTOR DATASHEET

(b) Terminal boxes		(b) IP 55
(6) Installation (Horizontal / Vertical)	-	HORIZONTAL
(7) Design ambient temperature	-	-15 TO 40°C
(8) Explosion proof (Required / Not required)	-	NOT REQUIRED
(9) Noise level (at full-load condition)	dB (A)	78
8. Characteristics		
(1) Current	A	(a) 1.71 (b) 0.9 (c) 9.47
(a) Normal current		
(b) No-load current		
(c) Starting current		
(2) Torque	%	(a) 215 (b) 280
(a) Starting torque		
(b) Maximum torque		
(3) Slip at rated output	%	5
(4) Efficiencies	%	(a) 77.4 (b) 78 (c) 76.3 (d) 71
(a) At 100% load		
(b) At 75% load		
(c) At 50% load		
(d) At 25% load		
(5) Power factor	%	(a) 85.5 (b) 45
(a) At rated load		
(b) At starting load		
(6) GD2 coupled with driven equipment	kg-m ²	0.005
(7) Starting time with driven equipment	-	1-2 SECONDS (DOL)
(8) Consecutive number of starts	s	(a) 5 (b) 3 (c) 5 min (d) 10 min
(a) From cold condition per hour		
(b) From hot condition per hour		
(c) Minimum time between 2 starts (running state)		
(d) Minimum time between 2 starts (stop state)		
(9) Allowable locked-rotor time	s	(a) 10 (b) 15
(a) At cold condition		
(b) At hot condition		

MOTOR DATASHEET

9. Constructions		
(1) Stator winding connection (Wye / Delta)	-	WYE/DELTA
(2) Type of bearing (DE / NDE)	-	6204ZZC3/ 6204ZZC3
(3) Lubricants (a) Recommended lubricant and brand name (b) Pouring method (c) Quantity of lubricant for initial filling (d) Recommended interval for recharging (e) Recharging quantity (f) Location of pouring (indicated in the outline drawing)	-	CAN'T BE RELUBRICATED
(4) Bearing cooling water requirement (if required) (a) Quantity (b) Inlet water temperature (c) Required cooling water pressure (d) Type of cooling water	(a) m ³ /h (b) °C (c) kPa (d) -	NOT REQUIRED
(5) Water to air heat exchanger (if applied) (a) Quantity of cooling water (b) Inlet water temperature (c) Required cooling water pressure (d) Type of cooling water	(a) m ³ /h (b) °C (c) kPa (d) -	NOT APPLICABLE
(6) Space heater (AC 220V 1 phase)	W	YES (15W)
(7) Weight	kg	16.5
10. Attached document numbers		
(1) Motor outline drawing	-	SEE ATTACHMENT
(2) Terminal box drawings (a) For main power (b) For instruments	-	SEE ATTACHMENT

MOTOR DATASHEET

(c) For space heater		
(3) Current transformers (for MV motors only) (a) Characteristics curves (b) Outline drawing	-	NOT APPLICABLE
(4) Efficiency curves	-	SEE ATTACHMENT
(5) Thermal capability curves (a) At cold condition (b) At hot condition	-	TBA
(6) Starting and speed torque characteristics at 80%, 90% and 100% voltage	-	SEE ATTACHMENT

SPECIFICATION TABLE OF 3-PHASE SQUIRREL CAGE INDUCTION MOTOR	CUSTOMER		
	INQ. NO.		EQUIPMENT
	JOB. NO.		MACHINE
	TOTAL SETS		ITEM NO.

ITEM	TERMS	DESCRIPTION				
1	Model	AESU2S				
2	Code or Standard	Dimensions	Frame Assignment	Performance	Test	
		IEC	TECO	IEC, GB	IEC, GB	
3	Rating	1 HP	2 Pole	380 Volt	3 Phase 50 Hz	
4	Service Duty	Continuous Rating S.F. 1.0				
5	Starting Method	D.O.L.				
6	Rotation	Bi-Direction				
7	Drive Method	Direct Coupling				
8	Environment	Amb.Temp. :	-15~40°C			
		Humidity : Less Than	90%RH			
		Altitude : Up to	1000M			
9	Enclosure & Protection	IP55 : Totally Enclosed				
10	Cooling	IC411 : Self External Fan, Surface Cooling				
11	Mounting	IM3001 : HS, Flange; IM3011 : VS, Flange;				
12	Dimensions	Dr#	TEK20171121015	Frame No :	80M	
13	Fan & Fan Cover	Fan: polypropylene	Fan Cover :	Steel Plate		
14	Terminal Box	Pressed Steel				
15	Lubricant	Mineral Oil , Li - Base Grease (MULTEMP SRL)				
16	Painting	Color : Munsell 5PB 3/8				
17	Stator Winding	Ins. Class F				
18	Starting Performance	LRC≤	9.47	Amp	LRT/FLT 215 %	
19	Operating Performance At Rated 380 Volt	%Load	100	75	50	Break Down Torque 280 %FLT
		Amp	1.71	1.39	1.13	
		Eff. %	77.4	78	76.3	Temp. Rise Limit(R) Stator: 80
		P.F. %	85.5	78.5	66	
		R.P.M	2850	2890	2926	
20	Note	C/w Space Heater 15W, 1Ph/220-240V/50Hz				
		<div style="border: 1px solid black; padding: 5px; display: inline-block;"> PRELIMINARY DATE: 19/03/2018 </div>				

APPD. Imtan	19/03/2018	TECO Electric & Machinery Co., Ltd.	DWG NO.
CHKD. Imtan	19/03/2018		TEK20171121015
DWN. Imtan	19/03/2018		PN Ver:03

TECO

OUTLINE DIMENSIONS

3-PHASE INDUCTION MOTOR

DWG. NO.
AESU2S020001YFKWA-
rev.00

Type	Output		Pole	Rating	Voltage	Hz	SYN.SPEED rpm
	HP	kW					
AESU2S KWA-	1	0.75	2	CONT.	380V	50	3000

TOTALLY ENCLOSED FAN COOLED TYPE. SQUIRREL-CAGE ROTOR

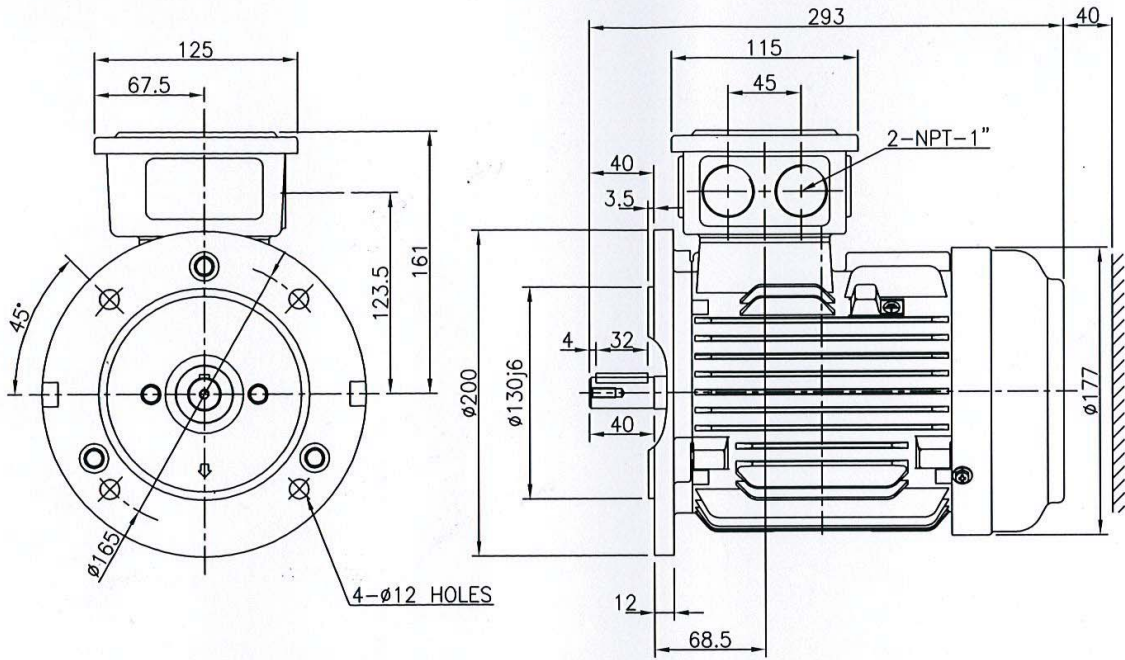

NOTE:-

1. Dimension in mm
2. Frame No. 80M
3. Class F Insulation
4. IP55
5. Cable Gland Not Supplied
6. Bearing : Drive End 6204ZZ
Non Drive End 6204ZZ

FOR REFERENCE ONLY

THREAD HOLE
M6 X 1.0P
DEPTH 16

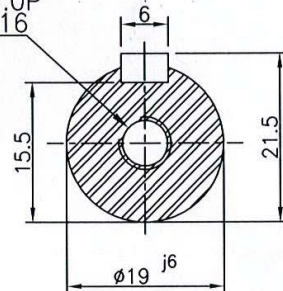

Accepted / Received by : _____
(Name)

Date : _____

Customer : NTK INDUSTRIAL SDN BHD

DRAWN	DAVE	05.07.2018
CHECKED	SP im	05.07.2018
APPROVED		05.07.2018

TECO ELECTRIC & MACHINERY SDN. BHD. (373361-P)
Plo 52, Jalan Firma 2/1, Kawasan Perindustrian Tebrau 1,
81100 Johor Bahru, Malaysia.
Tel : 07-3548008 Fax : 07-3546107