

ASSEMBLY AND DISASSEMBLY with THRUST BEARING

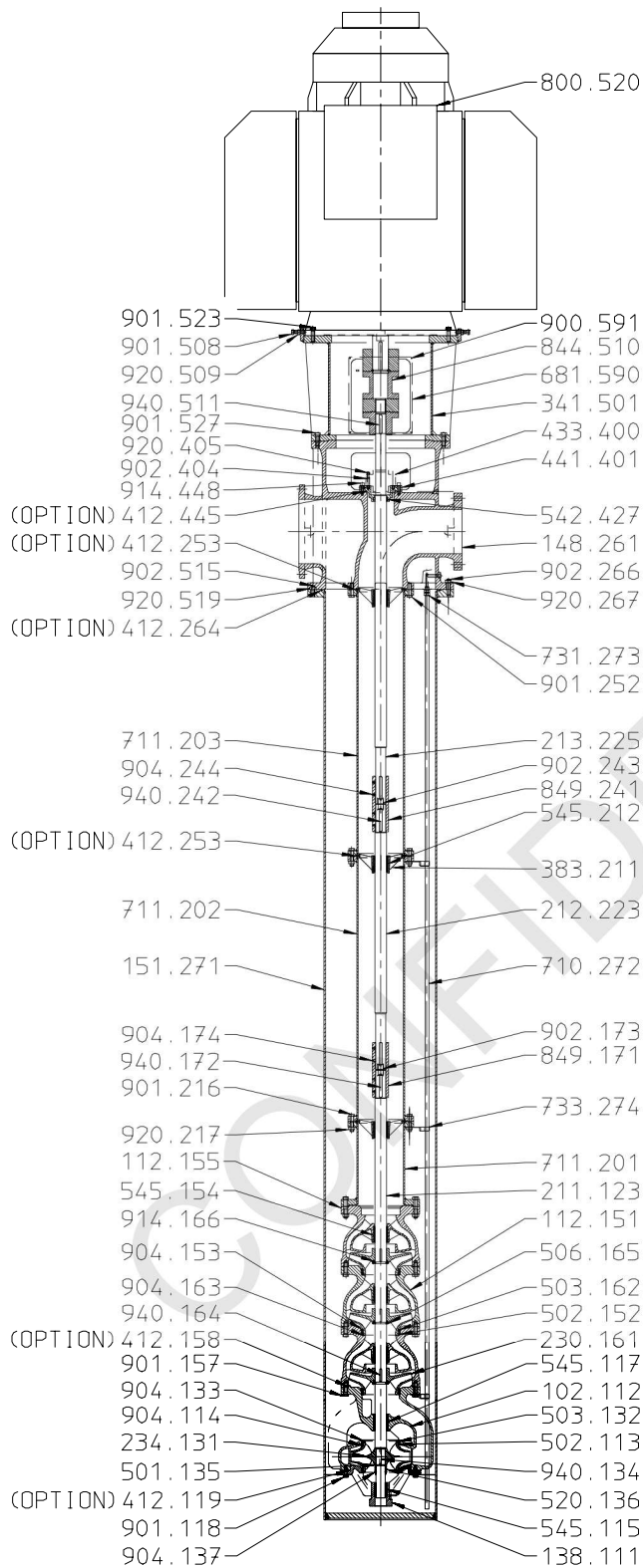

Find No.	Description
138.111	Suction Bell
112.112	Bowl (First)
502.113	Stationary Ring (Suction Bell)
904.114	Set Screw (Suction Bell Ring)
545.117	Bearing Bushing (First Bowl)
901.118	Capscrew, Hex Head (Suction Bell-Bowl)
914.121	Capscrew, Socket Head (Impeller Hub Cap)
260.122	Impeller Hub Cap
211.123	Pump Shaft
231.131	Suction Impeller
503.132	Impeller Ring (Suction Impeller)
904.133	Set Screw (Suction Impeller Ring)
940.134	Key (Suction Impeller)
112.151	Bowl (Series)
502.152	Stationary Ring (Bowl)
904.153	Set Screw (Bowl Rings)
545.154	Bearing Bushing (Bowl)
112.155	Bowl (Top Series)
901.157	Capscrew, Hex Head (Bowl-Bowl)
230.161	Impeller (Series)
503.162	Impeller Ring (Series Impeller)
904.163	Set Screw (Series Impeller Rings)
940.164	Key (Series Impeller)
506.165	Retaining Ring
914.166	Capscrew, Socket Head (Retaining Ring)
849.171	Sleeve Coupling
852.171	Screwed Coupling (Not Shown)
940.172	Key (Sleeve Coupling)
902.173	Stud (Sleeve Coupling)
904.174	Set Screw (Sleeve Coupling)
711.201	Column
383.211	Bearing Spider Housing
545.212	Bearing Bushing (Bearing Spider)
901.216	Capscrew, Hex Head (Bowl-Column)
920.217	Nut (Bowl-Column)
213.225	Head Shaft
901.252	Capscrew, Hex Head (Column-Head)
148.261	Suction & Discharge Head
903.262	Threaded Plug (Gauges)
903.263	Threaded Plug (Drain)
412.264	O-ring (Head-Barrel, Inner)
412.265	O-ring (Head-Barrel, Outer)
902.266	Stud (Head-Barrel)
920.267	Nut (Head-Barrel)
151.271	Barrel
710.272	Tubing (Drain)
731.273	Tube Fitting
733.274	Pipe Clamp
433.400	Mechanical Seal
441.401	Seal Housing
902.404	Stud (Mechanical Seal - Seal Housing)
920.405	Nut (Mechanical Seal - Seal Housing)
542.427	Throttle Bushing
412.445	O-ring (Seal Housing-Head)
914.448	Capscrew, Socket Head (Seal Housing-Head)
341.501	Driver Stand
901.508	Capscrew, Hex Head (Driver Alignment)
920.509	Nut (Driver Alignment)
843.510	Flexible Coupling
940.511	Key (Flexible Coupling)
800.520	Motor
901.523	Capscrew, Hex Head (Driver-Driver Stand)
901.527	Capscrew, Hex Head (Driver Stand-Head)
681.590	Coupling Guard
900.591	Screw (Coupling Guard)

DOUBLE SUCTION
STANDARD CONFIGURATION