

TEXJ SERIES DATA

PERFORMANCE DATA-6.6kV (4 POLE)

OUTPUT		FULL LOAD rpm	FRAME No.	EFFICIENCY			POWER FACTOR			CURRENT		TORQUE			ROTOR GD ² kg-m ²	APPROX. WEIGHT kg
kW	HP			FULL LOAD (%)	3/4 LOAD (%)	1/2 LOAD (%)	FULL LOAD (%)	3/4 LOAD (%)	1/2 LOAD (%)	FULL LOAD (A)	LOCKED ROTOR (%)	FULL LOAD kg-m	LOCKED ROTOR %FLT	BREAK-DOWN %FLT		
160	215	1486	355	94.6	94.3	93.4	83.4	79.5	70.3	18	680	104.9	80	200	21.50	2350
185	250	1486	355	94.7	94.5	93.5	83.5	79.6	70.5	20	680	121.3	80	200	24.00	2400
200	270	1486	355	94.8	94.5	93.5	83.6	79.6	70.5	22	680	131.1	80	200	26.00	2470
220	300	1488	355	94.9	94.6	93.6	83.7	79.7	70.6	24	685	144.0	80	200	28.50	2550
250	335	1488	355	95.0	94.7	93.7	83.8	79.8	70.7	27	685	163.6	80	200	30.00	2600
280	375	1488	355	95.1	94.8	93.8	83.9	79.8	70.8	31	680	183.3	80	200	32.50	2680
315	420	1488	355	95.2	94.9	93.9	84.0	79.9	70.9	34	680	206.2	80	210	35.00	2740
355	475	1488	355	95.3	95.0	94.0	84.0	80.0	71.0	39	685	232.4	80	210	38.60	2780
400	535	1488	355	95.3	95.1	94.3	84.1	80.1	71.0	44	624	261.8	80	210	41.10	2840
425	570	1488	355	95.4	95.2	94.5	84.5	80.8	72.2	46	611	278.2	80	210	43.40	2920
450	600	1489	355	95.4	95.2	94.5	83.9	79.9	70.6	49	647	294.4	90	230	47.40	3050
500	670	1489	355	95.5	95.4	94.7	83.8	79.7	70.3	55	648	327.1	90	230	50.50	3120
510	680	1489	355	95.6	95.5	94.8	83.9	80.0	70.8	56	637	333.6	90	230	50.50	3120
540	720	1489	355	95.7	95.6	95.0	85.0	81.6	73.2	58	626	353.2	90	220	55.30	3270
560	750	1489	355	95.8	95.7	95.1	84.2	80.4	71.4	61	644	366.3	90	230	55.30	3280
630	845	1490	400	96.0	95.8	95.2	82.6	78.7	69.4	69	628	411.8	80	210	81.00	4120
670	900	1490	400	96.1	96.0	95.4	82.7	78.9	69.8	74	628	438.0	80	210	83.40	4210
710	950	1490	400	96.2	96.1	95.5	82.6	78.6	69.2	78	651	464.1	90	220	89.40	4340
750	1000	1490	400	96.2	96.1	95.5	82.8	78.9	69.7	82	640	490.3	90	220	93.00	4440
800	1070	1490	450	96.2	96.0	95.4	83.4	80.4	72.3	87	594	523.0	80	200	156.9	5090
830	1110	1490	450	96.2	96.1	95.5	83.7	80.7	72.9	90	594	542.6	80	200	164.0	5240
900	1200	1490	450	96.3	96.1	95.6	83.3	79.7	71.4	98	639	588.3	90	210	180.4	5500
1000	1340	1490	450	96.4	96.3	95.7	83.6	80.4	72.4	109	637	653.7	90	210	196.7	5780
1050	1410	1490	450	96.4	96.3	95.8	83.8	80.6	72.8	114	639	686.4	90	210	206.1	5940
1120	1500	1492	500	96.5	96.1	95.2	81.8	77.5	67.7	124	623	731.2	70	230	209.2	6640
1250	1675	1492	500	96.6	96.3	95.4	82.5	78.5	69.2	137	630	816.0	70	230	233.4	7050
1400	1875	1492	500	96.7	96.4	95.6	82.9	78.9	69.8	153	648	913.9	70	230	260.7	7510
1600	2145	1492	500	96.8	96.5	95.8	82.8	78.8	69.5	175	661	1045	70	230	291.0	8060

NOTE:

1. The above are typical values based on test according to IEC 60034
2. Tolerance according to IEC 60034-1.
3. Breakdown & Locked rotor torques are show as average expected voltages.
4. Efficiency, power factor, speed and torque are the same for other voltages.
Current values vary inversely with voltage.
5. Data subject to change without prior notice.

TEXJ SERIES DATA

PERFORMANCE DATA-6.6kV (6 POLE)

OUTPUT		FULL LOAD rpm	FRAME No.	EFFICIENCY			POWER FACTOR			CURRENT		TORQUE			ROTOR GD ² kg-m ²	APPROX. WEIGHT kg
kW	HP			FULL LOAD (%)	3/4 LOAD (%)	1/2 LOAD (%)	FULL LOAD (%)	3/4 LOAD (%)	1/2 LOAD (%)	FULL LOAD (A)	LOCKED ROTOR (%)	FULL LOAD kg-m	LOCKED ROTOR %FLT	BREAK-DOWN %FLT		
160	215	990	355	94.4	93.8	92.7	72.2	64.9	52.8	21	630	157.4	90	230	31.50	2730
185	250	990	355	94.5	94.0	92.8	72.8	65.5	53.2	24	630	182.0	90	230	37.00	2760
200	270	990	355	94.6	94.1	93.0	73.0	66.0	53.7	25	630	196.8	90	230	42.00	2800
220	300	991	355	94.7	94.2	93.1	73.9	66.8	54.3	28	630	216.2	90	230	48.00	2850
250	335	991	355	94.8	94.3	93.3	74.5	67.2	54.8	31	620	245.7	90	230	53.00	2900
280	375	991	355	94.9	94.5	93.4	75.7	68.2	55.1	34	605	275.2	110	230	56.20	2960
300	400	991	355	95.0	94.7	93.6	76.5	69.3	55.8	36	609	294.9	110	230	59.30	3030
315	420	991	355	95.1	94.8	93.9	77.2	70.5	58.1	38	618	309.6	100	230	59.30	3030
355	475	991	355	95.3	95.1	94.2	78.4	72.1	60.1	42	627	348.9	100	230	66.50	3190
400	535	991	355	95.3	95.1	94.3	78.7	72.6	60.2	47	632	393.1	100	230	74.60	3400
425	570	991	355	95.5	95.3	94.5	77.6	71.0	58.1	50	627	417.7	100	230	77.70	3450
450	600	991	400	95.6	95.4	94.7	81.5	75.7	64.5	51	655	442.3	85	230	102.1	4040
500	670	991	400	95.8	95.7	95.0	82.5	77.0	66.4	55	667	491.4	80	230	108.4	4130
510	680	991	400	95.8	95.7	95.1	82.7	77.4	67.0	56	670	501.3	80	230	108.4	4130
540	720	991	400	95.8	95.7	95.0	81.9	76.3	65.2	60	664	530.7	85	230	118.0	4300
560	750	991	400	95.9	95.8	95.2	82.5	76.9	66.2	62	668	550.4	80	230	118.0	4300
630	845	991	400	96.0	95.9	95.4	82.6	77.3	66.7	70	669	619.2	90	230	137.1	4660
670	900	992	450	96.1	95.8	95.0	84.5	79.9	69.8	72	743	657.8	90	230	234.4	5300
710	950	992	450	96.2	95.9	95.1	85.2	81.0	71.7	76	720	697.1	90	230	249.8	5510
750	1000	992	450	96.2	96.0	95.2	85.7	81.9	73.0	80	708	736.4	80	230	265.3	5700
800	1070	992	450	96.2	96.0	95.3	85.8	82.3	74.1	85	686	785.5	80	230	280.7	5920
900	1200	993	500	96.3	96.0	95.3	82.9	78.6	69.0	99	608	882.8	80	230	296.7	6820
1000	1340	993	500	96.4	96.2	95.4	82.9	78.6	68.8	109	623	980.9	85	230	332.3	7300
1120	1500	993	500	96.5	96.3	95.6	83.0	78.6	68.7	122	647	1099	90	230	379.7	7840
1250	1675	993	500	96.6	96.4	95.9	84.1	80.7	72.3	135	588	1226	80	210	415.3	8290

NOTE:

1. The above are typical values based on test according to IEC 60034
2. Tolerance according to IEC 60034-1.
3. Breakdown & Locked rotor torques are show as average expected voltages.
4. Efficiency, power factor, speed and torque are the same for other voltages.
Current values vary inversely with voltage.
5. Data subject to change without prior notice.

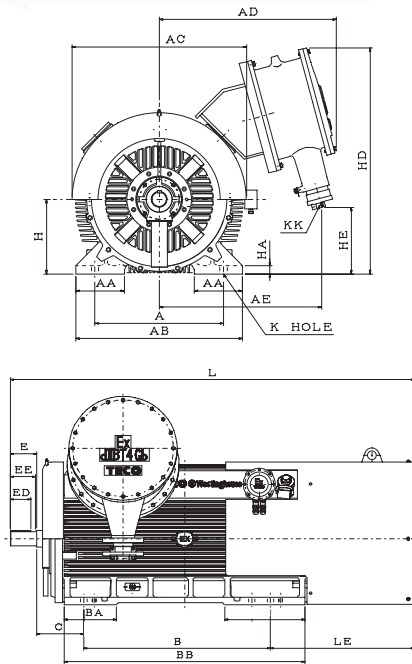

FIG. 3

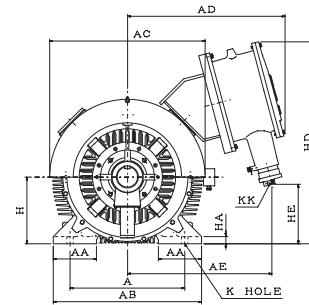
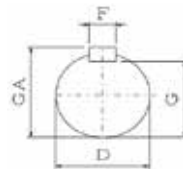
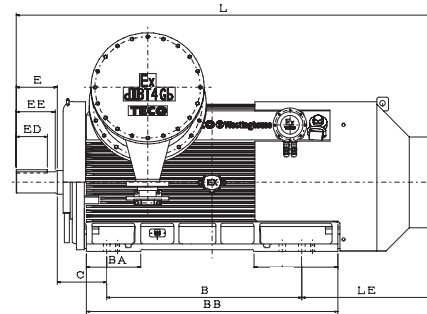

FIG. 4



FRAME SIZE	H	HA	HD	HE	K	L	LE	KK	SHAFT EXTENSION							BEARING	
									D	E	ED	EE	F	G	GA	DRIVE END	OPPOSITE DRIVE END
355DA-70R	355	40	1080	315	28	2165	770	Note 4	70	140	110	134	20	62.5	74.5	6218C3	6315C3
400DA-85R	400	40	1150	385	35	2340	770	Note 5	85	170	140	165	22	76	90	6218C3	6218C3
450DA-85R	450	50	1235	470	35	2555	820	Note 5	85	170	140	164	22	76	90	6220C3	6220C3
355DB-110R	355	40	1080	315	28	2125	660	Note 4	110	210	160	200	28	100	116	6224	6220
400DB-125R	400	40	1150	385	35	2280	670	Note 5	125	210	160	202	32	114	132	6226	6222
450DB-140R	450	50	1235	470	35	2480	665	Note 5	140	250	200	240	36	128	148	6230	6226
500DB-160R	500	50	1335	570	35	2690	655	Note 5	160	300	250	290	40	147	169	6334	6330

NOTE:

1. All dimensions are in mm.
2. Tolerance of shaft end diameter D : 1) $\phi 70 \sim \phi 160$: m6
3. Tolerance of shaft center height H : 1) 355~500 : +0, -1
4. Usable Shaft Length : EE
5. M75x1.5 or NPT 3" , Cable Outer Diameter not to exceed 63mm when rubber sheathed is used.
6. M90x2 or NPT 3.5" , Cable Outer Diameter not to exceed 63mm when rubber sheathed is used.
7. Data subject to change without prior notice.

TECO Electric & Machinery Pte Ltd

47 Tuas Ave 9,
Singapore 639190

Tel: +65 6265 4622 (General)
Tel: +65 6263 9269 (Local Sales)
Tel: +65 6263 9278 (Export Sales)

Fax: +65 6268 8651 (General)
Fax: +65 6265 7354 (Local Sales)
Fax: +65 6265 7354 (Export Sales)

Website: www.teco.com.sg
Email: ds@teco.com.sg (Local Sales)
Email: es@teco.com.sg (Export Sales)

TECO ELECTRIC & MACHINERY SDN BHD (MALAYSIA HQ)**TYM Electric & Machinery Sdn Bhd**

PLO 52 (No.26), Jalan Firma 2/1,
Kawasan Perindustrian Tebrau 1,
81100 Johor Bahru, Johor,
Malaysia

Contact Person: Mr Y.S.Liew

Tel: (60) 7-3548008
Fax: (60) 7-3546107, (60) 7-3545017
Email: sales@teco.com.my

**TECO ELECTRIC & MACHINERY
(THAI) CO., LTD**

128/1 Soi Watsrivareenoi, Moo 7,
Bangna Trad Road, Km. 18,
Bangchalong, Bangplee,
Samuthprakarn 10540
Thailand

Contact Person: Mr Pisut Sae Chong

Tel: (662) 3371311 ~ 20
Fax: (662) 3371630 ~ 1
Email: sales@teco.co.th

**TECO (VIETNAM)
ELECTRIC & MACHINERY CO., LTD**

Long Thanh Industrial Zone
Long Thanh Distric, Dong Nai Province
Vietnam

Contact Person: Mr Hang Quang Dung

Tel: (84) 61-3514 108
Fax: (84) 61-3514 110
Email: sales@teco.com.vn

**PT.TECO MULTIGUNA ELEKTRO
(INDONESIA)**

Jl Bandengan Utara No.83/1-2-3
Jakarta 14440
Indonesia

Contact Person: Mr Abraham Anggara

Tel: (62-21) 6622201
Fax: (62-21) 6697029
Email: marketing@teco.id

**TECO INDUSTRIAL SYSTEM PVT
LTD (INDIA)**

No. 351 F.I.E.
Patpar Ganj Industrial Area
Delhi 110092
India

Contact Person: Mr. Suvek Kumar

Tel: (91) 11 22158705
Mobile: (91) 9540033881
Email: suvek@teco.co.in

The logo for TECO, featuring the word "TECO" in a bold, blue, sans-serif font. To the right of the text is a circular icon composed of several curved, overlapping segments in shades of blue and orange, creating a stylized, dynamic shape.