

## 4.1.1 Specifications

### Rating and characteristics

Table 4.1.1 (1)

Type	SR-SRD-	N4 (CX)	N4JH (CX)	N4LC (CX)		
Available contact arrangements (code)		4NO (4A) 3NO+1NC (3A1B) 2NO+2NC (2A2B)	4NO (4A) 2NO+2NC (2A2B)	4NO (4A) 2NO+2NC (2A2B)		
Rated insulation voltage		V				
Conventional free air thermal current		lth	A	660		
Rated operating current			A	16		
Rated operating current	Category AC-15 (coil load)	110VAC	A	6	10	6 (3) <sup>2</sup>
		230VAC	A	5	10	5 (3) <sup>2</sup>
		440VAC	A	3	5	3 (3) <sup>2</sup>
		550VAC	A	3	4	3 (3) <sup>2</sup>
	Category AC-12 (resistive load)	110VAC	A	16	20	16
		230VAC	A	12	16	12
		440VAC	A	5	10	5
		550VAC	A	5	10	5
	Category DC-13 (large coil load)	24VDC	A	5		3
		48VDC	A	3		2
		110VDC	A	0.8(2) <sup>1</sup>		0.5
		220VDC	A	0.2(0.8) <sup>1</sup>		0.1
	Category DC-14	24VDC	A	8		5
		48VDC	A	3		2
		110VDC	A	2(4) <sup>1</sup>		1
		220VDC	A	0.4(1) <sup>1</sup>		0.2
	Category DC-12 (resistive load)	24VDC	A	10		8
		48VDC	A	8		5
		110VDC	A	5(8) <sup>1</sup>		3
		220VDC	A	1(3) <sup>1</sup>		0.5
Mechanical life	Operations	10 million (latched type 1 million)				
Electrical life	Operations	0.5 million				
Permissible ambient temperature/humidity		°C/%RH	-25 to +55/45 to 85			
Coil consumption	Ac-operated	Inrush	VA	60		
		Sealed	VA	10		
	DC-operated	Watts	W	3		
		Watts	W	7		
Coil voltage tolerance		times	0.85 to 1.1 (rated coil voltage)			
Operating time (average)	Make	ms	15 (AC)	50 (DC)		
	Break	ms	10 (operated)	10 (operated)		
Switching frequency		operations /hour	1,800			
Vibration resistance	10-55Hz	m/s <sup>2</sup>	19.6			
Shock resistance	10 msec. half sine wave	m/s <sup>2</sup>	49			
Conductor size		mm <sup>2</sup>	1.0 to 2.5			

Notes: 1. Parenthesized rated operating current is for switching the load in 2-pole series connection.

2. Parenthesized rated operating current is for switching of NC contact.

### Coil voltage

Table 4.1.1 (2)

Coil designation	Rated voltage (AC)		Coil designation	Rated voltage (AC)		Coil designation	Rated voltage (DC)
	50Hz	60Hz		50Hz	60Hz		
AC12V	12V	12V	AC220V	208-220V	220V	DC24V	24VDC
AC24V	24V	24V	AC230V	220-240V	230-240V	DC48V	48VDC
AC48V	48-50V	48-50V	AC260V	240-260V	260-280V	DC100V	100VDC
AC100V	100V	100-110V	AC380V	346-380V	380V	DC110V	110VDC
AC120V	110-120V	115-120V	AC400V	380-415V	400-440V	DC125V	120-125VDC
AC127V	125-127V	127V	AC440V	415-440V	460-480V	DC200V	200VDC
AC200V	200V	200-220V	AC500V	500V	500-550V	DC220V	220VDC

Note: AC operated coils are the same as those of S-N10 etc., and DC operated coils are the same as those of SD-N11 etc.

## 4.1.2 Auxiliary Contact Blocks

### Type Designation

#### ● Front clip-on types

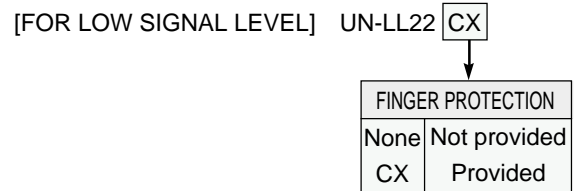
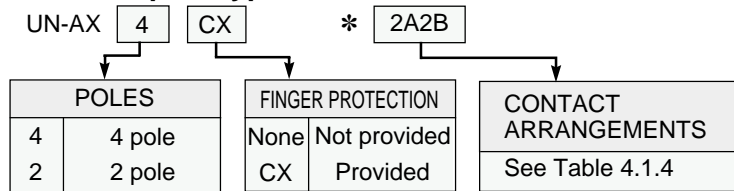

#### ● Side clip-on types

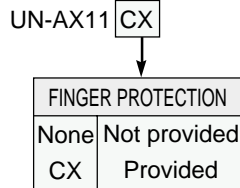

Note: Mark \* indicates a blank space.

### ■ Ratings and characteristics

Table 4.1.2 (1)

Type	UN-	AX2 (CX)	AX4 (CX)	AX11(CX)	LL22 (CX)	
Applicable contact arrangements		2NO 1NO+1NC 2NC	4NO 3NO+1NC 2NO+2NC	1NO+1NC	1NO+1NC [Standard]	1NO+1NC' [Low level]
Rated insulation voltage	V	690				250
Conventional free air thermal current	lth	A	16		1	
Rated operating current	Category AC-15 (coil load)	110VAC	A		6	
		220VAC	A		5	
		440VAC	A		3	
Category DC-13 (large coil load)	48VDC	A		3		
	110VDC	A		0.8		
	220VDC	A		0.2		
Mechanical life	operations	10 million		2.5 million		
Electrical life	operations	0.5 million		0.5 million		
Permissible ambient temperature/humidity	°C/%RH	-25 to +55/45 to 85				
Switching frequency	operations /hour	1,800				
Conductor size	mm <sup>2</sup>	1.0 to 2.5				

Note: 1. Contact reliability may be decreased if it is operated more than 1 million operations

### ■ Selection guide & contact arrangements

Table 4.1.2 (2)

Front clip-on types	UN-AX2 2A		UN-AX2 1A1B		UN-AX2 2B		UN-LL22	
	UN-AX4 4A		UN-AX4 3A1B		UN-AX4 2A2B			1NO+1NC, 1NO+1NC
	UN-AX11							
Side clip-on types	When mount on left side		When mount on right side					

Note: Front clip-on types and side clip-on contact block should not be mounted both.

### 4.1.3 Contact Arrangements of Contactor Relay

Table 4.1.3

With standard contacts		
<p>4NO</p> <p>SR-N4(CX)AC.....V 4A SRD-N4(CX)DC.....V 4A</p>	<p>3NO + 1NC</p> <p>SR-N4(CX)AC.....V 3A1B SRD-N4(CX)DC.....V 3A1B</p>	<p>2NO + 2NC</p> <p>SR-N4(CX)AC.....V 2A2B SRD-N4(CX)DC.....V 2A2B</p>
With big capacity contacts		
<p>4NO</p> <p>SR-N4JH(CX)AC.....V 4A SRD-N4JH(CX)DC.....V 4A</p>	/	<p>2NO + 2NC</p> <p>SR-N4JH(CX)AC.....V 2A2B SRD-N4JH(CX)DC.....V 2A2B</p>
With late break contacts		
/	<p>3NO + 1NC (late break)</p> <p>SR-N4LC(CX)AC.....V 3A1B SRD-N4LC(CX)DC.....V 3A1B</p>	<p>2NO + 2NC (late break)</p> <p>SR-N4LC(CX)AC.....V 2A2B SRD-N4LC(CX)DC.....V 2A2B</p>
With mechanical latching		
<p>4NO</p> <p>SRL-N4 AC.....V 4A SRLD-N4 DC.....V 4A</p>	<p>3NO + 1NC</p> <p>SRL-N4 AC.....V 3A1B SRLD-N4 DC.....V 3A1B</p>	<p>2NO + 2NC</p> <p>SRL-N4 AC.....V 2A2B SRLD-N4 DC.....V 2A2B</p>

### 4.1.4 Spare Coils & Accessories

Spare coils and accessories are common with the series S-N contactors.

- Spare coils ..... See Table 1.8.1 (except for Type SRL(D) latched relays)
- Surge absorbers (suppressors) ..... See Table 1.8.6

### 4.1.5 Outline Dimensions

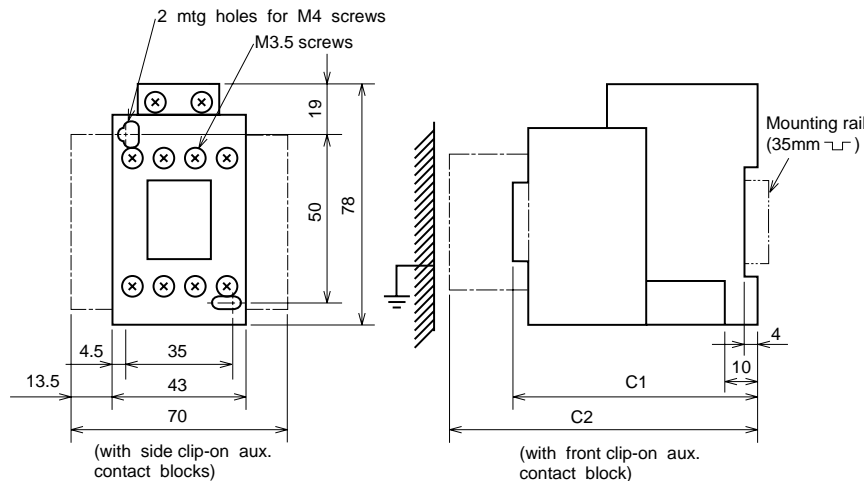

#### • Key to Dimensions

Model	C1	C2	Mass (kg)
SR-N4(CX)	78	106	0.3
SRD-N4(CX)	110	138	0.62
SRL-N4(CX) SRLD-N4(CX)	134	-	0.45

Note: Front clip-on and side clip-on contact block should not be mounted both.