

Tanjung Jati B Expansion (Jawa-4) Coal Fired Steam Power Plant 2 x 1,000 MW
Initial Spare Part List (LOT 3)

Item No.	Equipment Tag Number (KKS)										Spec No.	Equipment Name	Description of Spare Items	Manufacturer's Part Identification	Qty per two Units		Sketch (See Item 2.11 of Instrm Sht)	Cross Reference Drawing (See Item 2.12 of Instrm Sht)	Frequency of replacement	Remarks	
	Level 0 (Total Plant)		Level 1 (System Code)				Level 2 (Equipment Code)								Level 3 (Component Code)					Item No. of CDA	Qty difference from Qty of CDA
	G	F ₀	F ₁ F ₁ F ₁	F ₁	A ₁ A ₂	A ₁	A ₂	B ₁ B ₂	B ₁	B ₂					Qty	(nr., pcs, set, etc)					
Coal Handling System -Coal Conveying System																					
1	0	0	EAC	01	AF	507					67.0403	Carry Idler's Roller BW1400		45	pcs		TJB56-L3-OFF-C-00-M-MAN-0030	24 months	B3-1-SP-61	123-45	
2	0	0	EAC	01	CH	507					67.0403	Flat Type Return Kiler's Roller BW1400		20	pcs		GP133-306-1600	24 months	B3-1-SP-65	24-20	
3	0	0	EAC	01	AT	301					67.0403	Pull Cord Switch		3	pcs		TJB56-L3-OFF-C-EAC-I-DAC-9000	24 months	B3-1-SP-74	5-3	
4	0	0	EAC	01	CS	501					67.0403	Belt Sway Switch		3	pcs		TJB56-L3-OFF-C-00-M-MAN-0032	24 months	B3-1-SP-75	5-3	
5	0	0	EAC	01	GP	001					67.0403	Speed Switch		1	pcs		TJB56-L3-OFF-C-EAC-I-DAC-9000	24 months	B3-1-SP-76	2-1	
6	0	0	EAC	01	GP	001					67.0403	LED Indicator or Lamp		10	pcs		TJB56-L3-OFF-C-BLJE-DLS-1220-1228	24 months	B3-1-SP-97	20-10	
7	0	0	EAC	01	GP	001					67.0403	Push Button		10	pcs		TJB56-L3-OFF-C-BLJE-DLS-1220-1228	24 months	B3-1-SP-99	5-10	
8	0	0	EAC	01	AF	507					67.0403	Selecting SW		10	pcs		TJB56-L3-OFF-C-BLJE-DLS-1220-1228	24 months	B3-1-SP-100	5-10	
9	0	0	EAC	01	AF	507					67.0403	Impact idler ø133*530		10	pcs		TJB56-L3-OFF-C-00-M-MAN-0030	24 months		New Item	
10	0	0	EAC	01	AF	507					67.0403	Comb idler ø133*1600		4	pcs		TJB56-L3-OFF-C-00-M-MAN-0030	24 months		New Item	
11	0	0	EAC	01	AF	507					67.0403	Spiral idler ø133*1600		5	pcs		TJB56-L3-OFF-C-00-M-MAN-0030	24 months		New Item	
12	0	0	EAC	01	AF	507					67.0403	Upper Carry Kiler ø159mm*900		25	pcs		TJB56-L3-OFF-C-00-M-MAN-0030	24 months		New Item	
13	0	0	EAC	01	AF	502					67.0403	Impact idler ø159mm*900		8	pcs		TJB56-L3-OFF-C-00-M-MAN-0030	24 months		New Item	
14	0	0	EAC	01	AF	502					67.0403	Return V type idler ø159mm*900		15	pcs		TJB56-L3-OFF-C-00-M-MAN-0030	24 months		New Item	
15	0	0	EAC	01	AF	502					67.0403	Comb idler ø159*1800		5	pcs		TJB56-L3-OFF-C-00-M-MAN-0030	24 months		New Item	
16	0	0	EAC	01	AF	502					67.0403	Spiral idler ø159*1800		5	pcs		TJB56-L3-OFF-C-00-M-MAN-0030	24 months		New Item	
17	0	0	EAC	01	AF	502					67.0403	Self alignment Guide idler ø108*180		25	pcs		TJB56-L3-OFF-C-00-M-MAN-0030	24 months		New Item	
18	0	0	EAC	01	AF	512					67.0403	Upper Carry Kiler ø159mm*750		5	pcs		TJB56-L3-OFF-C-00-M-MAN-0030	24 months		New Item	
19	0	0	EAC	01	AF	512					67.0403	Impact idler ø159mm*750		5	pcs		TJB56-L3-OFF-C-00-M-MAN-0030	24 months		New Item	
20	0	0	EAC	01	AF	512					67.0403	Return flat idler ø159*2200		1	pcs		TJB56-L3-OFF-C-00-M-MAN-0029	24 months		New Item	
21	0	0	EAC	01	AF	512					67.0403	Carry Kiler ø159mm*514		25	pcs		TJB56-L3-OFF-C-00-M-MAN-0029	24 months		New Item	
22	0	0	EAC	01	AF	512					67.0403	Press idler ø133*750		8	pcs		TJB56-EAC-M1902	12 months		New Item	
23	0	0	EAC	10	CG	331					67.0403	Emergency Switch for Fluid Coupling		1	pcs		TJB56-L3-OFF-C-00-M-MAN-0048	24 months		New Item	
24	0	0	EAC	10	CG	332					67.0403	Fusible plug		5	pcs		TJB56-L3-OFF-C-00-M-MAN-0048	24 months		New Item	
Coal Sampling																					
25	0	0	EBU	01	AT	502					67.0403	V-belt		3	pcs		TJB56-L3-OFF-C-00-M-MAN-0033	24 months		New Item	
Vibrating Screen																					
26	0	0	FBU	01	AT	513					67.0403	V-belt		2	pcs		TJB56-L3-OFF-C-00-M-MAN-0042	12 months		New Item	
27	0	0	EBU	01	AT	513					67.0403	Coil spring		2	pcs		TJB56-L3-OFF-C-00-M-MAN-0042	12 months		New Item	
Vibrating Feeder																					
28	0	0	ECA	01	AF	071					67.0403	Coil spring		1	pcs		TJB56-L3-OFF-C-00-M-MAN-0041	24 months		New Item	
29	0	0	ECA	01	AF	071					67.0403	Dust sealing parts for feeder		1	pcs		TJB56-L3-OFF-C-00-M-MAN-0041	24 months		New Item	
HVAC																					
30	0	0	ECA	01	AT	501					67.0403	Intake Valve		2	pcs		TJB56-L3-OFF-C-00-M-MAN-0032	12 months		New Item	
31	0	0	ECA	01	AT	501					67.0403	Solenoid Valve		2	pcs		TJB56-L3-OFF-C-00-M-MAN-0032	12 months		New Item	
DUST SUPPRESSION																					
32	0	0	GHA	71	AA	006					67.0403	Solenoid valve (Normal type)		1	pcs		TJB56-L3-OFF-C-00-M-MAN-0091	24 months		New Item	
33	0	0	GHA	71	AA	006					67.0403	Solenoid valve (Explosion-proof)		1	pcs		TJB56-L3-OFF-C-00-M-MAN-0091	24 months		New Item	
34	0	0	GHA	71	AA	006					67.0403	Check valve		1	pcs		TJB56-L3-OFF-C-00-M-MAN-0091	24 months		New Item	
35	0	0	GHA	71	AA	006					67.0403	Ball valve		1	pcs		TJB56-L3-OFF-C-00-M-MAN-0091	24 months		New Item	
36	0	0	GHA	71	AA	006					67.0403	Spray nozzle		2	pcs		TJB56-L3-OFF-C-00-M-MAN-0091	24 months		New Item	
Electrical																					
37	0	0	EAC	00	GP	001					67.0403	Lamps (normal)		1	pcs		TJB56-L3-OFF-C-EAC-E-DSU-0855	24 months		New Item	
38	0	0	EAC	00	GP	001					67.0403	Lamps (anti-explosion)		1	pcs		TJB56-L3-OFF-C-EAC-E-DSU-0855	24 months		New Item	
39	0	0	EAC	00	GP	001					67.0403	Lighting fixture (normal)		1	pcs		TJB56-L3-OFF-C-EAC-E-DSU-0855	24 months		New Item	
40	0	0	EAC	00	GP	001					67.0403	Lighting fixture (anti-explosion)		1	pcs		TJB56-L3-OFF-C-EAC-E-DSU-0855	24 months		New Item	
41	0	0	EAC	00	GP	001					67.0403	Intermediate relay		1	pcs		TJB56-L3-OFF-C-EAC-E-DSU-0855	24 months		New Item	
42	0	0	EAC	00	GP	001					67.0403	Air circuit breaker		1	pcs		TJB56-L3-OFF-C-BLJE-DLS-1220-1228	24 months		New Item	
Control and Instrumentation																					
43	0	0	EAC	51	CI	301					67.0403	Coal flow detector		1	pcs		TJB56-L3-OFF-C-EAC-I-DAC-9000	24 months		New Item	
44	0	0	EAC	51	CI	301					67.0403	Plug detector		1	pcs		TJB56-L3-OFF-C-EAC-I-DAC-9000	24 months		New Item	
45	0	0	EAC	10	EH	201					67.0403	Rip detector		1	pcs		TJB56-L3-OFF-C-EAC-I-DAC-9000	24 months		New Item	
45	0	0	EAC	10	EH	201					67.0403	Horn		1	pcs		TJB56-L3-OFF-C-EAC-I-DAC-9000	24 months		New Item	
Coal Handling System -Stacker Reclaimer																					
57											67.0402	bucket		4	pcs		TJB56-L3-OFF-C-EAD-M-DGA-0009&0006 Item 3-13,16	About 12 months		New Item	
58											67.0402	bucket tooth	ZGMn13	32	pcs		TJB56-L3-OFF-C-EAD-M-DGA-0009&0006 Item 1,2,24,25	About 9-12months		New Item	
59											67.0402	wearable scaleboard of furcate hopper	NM400	8	pcs		TJB56-L3-OFF-C-EAD-M-DGA-1076 Item 10	About 9-12months		New Item	
60											67.0402	wearable scaleboard of furcate hopper	NM400	8	pcs		TJB56-L3-OFF-C-EAD-M-DGA-1082 Item 21	About 9-12months		New Item	
61											67.0402	Rubber plate	for belt conveyor	12	pcs		TJB56-L3-OFF-C-EAD-M-DGA-1076 Item 11	About 6 months		New Item	
62											67.0402	Rubber plate	for belt conveyor	22	pcs		TJB56-L3-OFF-C-EAD-M-DGA-1082 Item 3	About 6 months		New Item	
63	0	0	EAD	2	AE	315	N/A	N/A	N/A		67.0402	slewing brake	for slow drive	2	pcs		TJB56-L3-OFF-C-EAD-M-DGA-0301	About 12-18 months		New Item	
64	0	0	EAD	2	AE	300	N/A	N/A	N/A		67.0402	shoe for belt conveyor brake	for boom conveyor	4	pcs		TJB56-L3-OFF-C-EAD-M-DGA-0191 0192 Item 3	About 12-18 months		New Item	
65	0	0	EAD	2	AE	300	N/A	N/A	N/A		67.0402	shoe for bucket wheel drive	for bucket wheel drive	4	pcs		TJB56-L3-OFF-C-EAD-M-DGA-0008	About 12-18 months		New Item	
66	0	0	EAD	2	AE	300	N/A	N/A	N/A		67.0402	fusible plug of bucket wheel fluid coupling	for belt conveyor brake	4	pcs		TJB56-L3-OFF-C-EAD-M-DGA-0008 Item 2	Safety part, replace as demand		New Item	
67	0	0	EAD	2	AE	300	N/A	N/A	N/A		67.0402	fusible plug of belt conveyor fluid coupling	for bucket wheel drive	4	pcs		TJB56-L3-OFF-C-EAD-M-DGA-0191 0192 Item 2	Safety part, replace as demand		New Item	
68	0	0	EAD	2	AE	300	N/A	N/A	N/A		67.0402	scaleboard of bottom hopper		16	pcs		TJB56-L3-OFF-C-EAD-M-DGA-1087-1089 Item 27	About 9-12months		New Item	
69	0	0	EAD	2	AE	300	N/A	N/A	N/A		67.0402	scaleboard of bucket wheel chute		40	pcs		TJB56-L3-OFF-C-EAD-M-DGA-1076 Item 8,9	About 9-12months		New Item	
70	0	0	EAD	2	AE	300	N/A	N/A	N/A		67.0402	scaleboard of tripper material quid chute		20	pcs		TJB56-L3-OFF-C-EAD-M-DGA-1077 Item 3,4	About 9-12months		New Item	
71	0	0	EAD	2	AE	300	N/A	N/A	N/A		67.0402	scaleboard of slewing steel structure hopper		16	pcs		TJB56-L3-OFF-C-EAD-M-DGA-1079 Item 2;	About 9-12months		New Item	
72	0	0	EAD	2	AE	300	N/A	N/A	N/A		67.0402	scaleboard of upper hopper		32	pcs		TJB56-L3-OFF-C-EAD-M-DGA-1078 Item 2;	About 9-12months		New Item	
73	0	0	EAD	2	AE	300	N/A	N/A	N/A		67.0402	scaleboard of material receive chute		16	pcs		TJB56-L3-OFF-C-EAD-M-DGA-1080 Item 4;	About 9-12months		New Item	
74	0	0	EAD	2	AE	300	N/A	N/A	N/A		67.0402	carry idler	ø133*600	40	pcs		TJB56-L3-OFF-C-EAD-M-DGA-0151 0152;	About 9-12months		New Item	
75	0	0	EAD	2	AE	300	N/A														

Tanjung Jati B Expansion Project
179956.67.0402
Bucket Wheel Stacker Reclaimer
Mechanical Operation and Maintenance Manual



The motor torque arm is support on the head boom. Bucket wheel body installed in the shaft which supported by two bearing blocks, the bucket wheel body connected with the shaft by high stress bolt , bucket wheel shaft connected to the bucket wheel drive by the means of shrink disk.

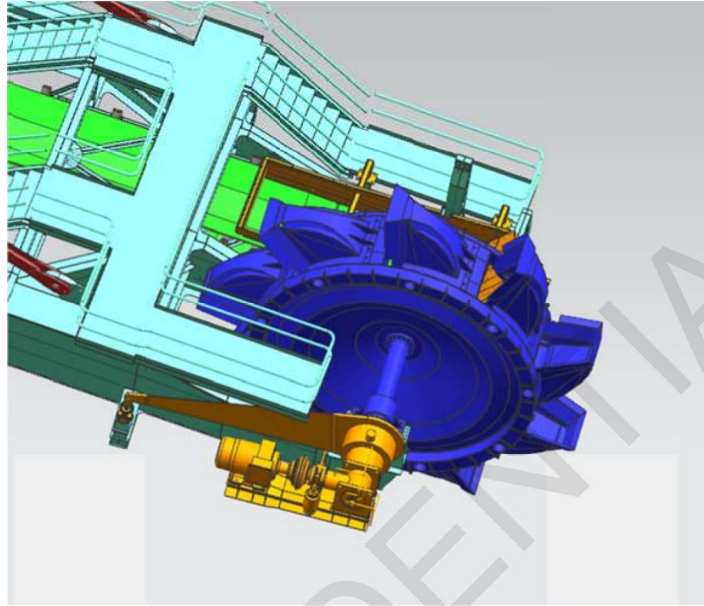

Figure 42. Bucket wheel Arrangement_(Plan View)

5.5.1.2 Technical Data

Machine Drawings:

Refer to Appendix Drawing

PROJECT DOCUMENT NO.	SUPPLIER DWG/DOC NO.	DWG/DOC TITLE
TJB56-L3-OFF-C-EAD-M-DGA-0004	B1260200100101	BUCKET WHEEL GENERAL ARRANGEMENT
TJB56-L3-OFF-C-EAD-M-DGA-0005	C2260200009905	BUCKET WHEEL BODY
TJB56-L3-OFF-C-EAD-M-DGA-0006	B2260200010688-01	BUCKET ASSEMBLY
TJB56-L3-OFF-C-EAD-M-DGA-0007	B2260200010689	BUCKET WHEEL DRIVE SHAFT ASSEMBLY
TJB56-L3-OFF-C-EAD-M-DGA-0008	B2260200012617	BUCKET WHEEL DRIVE DEVICE
TJB56-L3-OFF-C-EAD-M-DGA-0009	B2260200010688-02	BUCKET ASSEMBLY
TJB56-L3-OFF-C-EAD-M-DGA-0010	B2260200003236	BUCKET WHEEL DRIVE BUFFER DEVICE
TJB56-L3-OFF-C-EAD-M-DGA-0011	G250002686	HYDRAULIC COUPLING
TJB56-L3-OFF-C-EAD-M-DGA-0012	G340005218	BUCKET WHEEL GEAR BOX
TJB56-L3-OFF-C-EAD-M-DGA-0013	G360003618	BUCKET WHEEL BRAKE