



Series  
201

# Side Mounted-Chamber Type Level Control

Operating Pressures to 500 PSIG, 34 bar, Hermetically Sealed Snap Switch Option

**Model 201 liquid level control** is designed for long life and reliable operation in chemical plants, refineries and industrial facilities. Stainless steel switching mechanism uses gravity return action instead of springs to prolong life. Weatherproof enclosure is standard. Heavy duty, welded steel float chamber is suitable for 500 psi at 750°F.

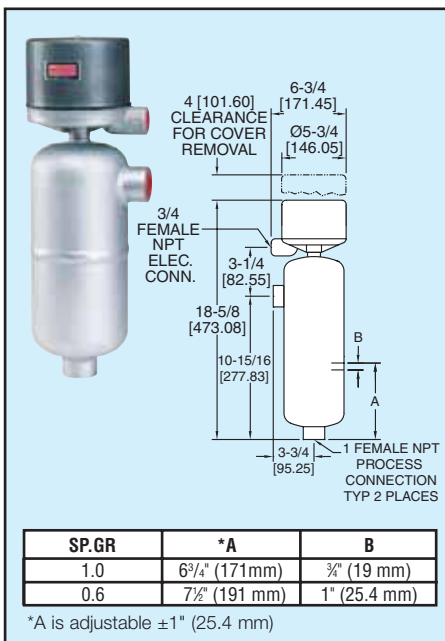

## SPECIFICATIONS

**Service:** Compatible liquids.  
**Wetted Materials:** Body: Carbon Steel. Optional 316 SS. Float and Trim: 303 SS, 304 SS, 316 SS, and 430 SS. Options of 316 SS and 430 SS or all 316 SS.  
**Temperature Limit:** Process: 750°F (399°C). Heat fins should be used for process temperatures above 500°F (260°C) with mercury switches, 400°F (204°C) with snap switches, and 350°F (176.7°C) with hermetically sealed snap switches.  
**Pressure Limit:** 600 psig (41 bar) at 100°F (37.7°C), 500 psig (34 bar) at 750°F (399°C). Higher ratings available.  
**Enclosure Rating:** NEMA 4X. Optional general purpose or explosion-proof.  
**Repeatability:** ±1/4" (6.4 mm).  
**Switch Type:** SPDT snap switch, hermetically sealed snap switch or mercury switch. Optional DPDT or two stage.

**Electrical Rating:** Snap Switch: 12A @ 120 VAC, 5A @ 240 VAC, 0.5A @ 125 VDC resistive, 0.25A @ 250 VDC resistive. Hermetically Sealed Snap Switch: 5A @ 125 VAC, 5A @ 240 VAC, 5A @ 30 VDC resistive. Mercury Switch: 4A @ 120 VAC/DC, 2A @ 240 VAC/DC. Higher contact ratings available for the Mercury switch.  
**Electrical Connections:** Screw terminal.  
**Conduit Connection:** 3/4" female NPT.  
**Process Connections:** 1" female NPT and 1" socket weld hub. Optional flange connections.  
**Mounting Orientation:** Vertical.  
**Set Point Adjustment:** ±1" (25.4 mm).  
**Weight:** 33 lb (14.97 kg).  
**Agency Approvals:** UL and CSA.  
**Specific Gravity:** 0.6 minimum.

## MODELS

Model Number	Switch Type
201-WT-4810-C1-60	SPDT Mercury
201-WT-7810-C1-60	SPDT Snap
201-WT-7810HM-C1-60	SPDT Hermetically Sealed Snap



Series  
391

# Side Mounted-Chamber Type Level Control

Compact, Low Cost, Hermetically Sealed Snap Switch Option

**Heavy duty and low cost** is the perfect description for the 391 Series level control. Stainless steel switching mechanism uses gravity return action instead of springs for long life. Weatherproof enclosure is standard. Welded steel chamber is good for 650 psig (45 bar) at 600°F (315°C).

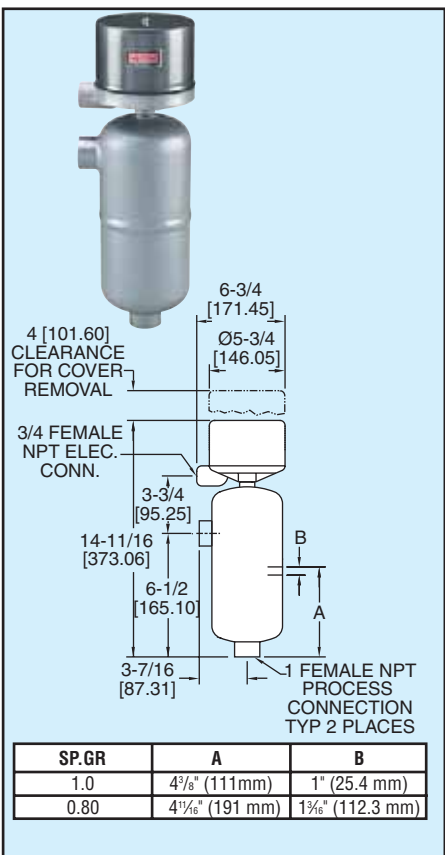

## Applications

Oil refineries, chemical plants, power generating stations, pumping stations, heat transfer systems, sanitary/waste water facilities, drip legs, hydraulic systems, boilers.

## SPECIFICATIONS

**Service:** Compatible liquids.  
**Wetted Materials:** Body: Carbon Steel. Float and Trim: 303 SS, 304 SS, 316 SS, and 430 SS.  
**Temperature Limit:** Process: 600°F (315.6°C). Heat fins should be used for process temperatures above 500°F (260°C) with mercury switches, 400°F (204°C) with snap switches, and 350°F (176.7°C) with hermetically sealed snap switches.  
**Pressure Limit:** 800 psig (55 bar) at 100°F (37.7°C), 650 psig (45 bar) at 600°F (315.6°C). Higher ratings available.  
**Enclosure Rating:** NEMA 4X. Optional general purpose or explosion-proof.  
**Switch Type:** SPDT snap switch, hermetically sealed snap switch or mercury switch. Optional DPDT.

**Electrical Rating:** Snap Switch: 12A @ 120 VAC, 5A @ 240 VAC, 0.5A @ 125 VDC resistive, 0.25A @ 250 VDC resistive. Hermetically Sealed Snap Switch: 5A @ 125 VAC, 5A @ 240 VAC, 5A @ 30 VDC resistive. Mercury Switch: 4A @ 120 VAC/DC, 2A @ 240 VAC/DC. Higher contact ratings available for the Mercury switch.  
**Electrical Connections:** Screw terminal.  
**Conduit Connection:** 3/4" female NPT.  
**Process Connections:** 1" female NPT. Optional 1" socket weld hub or flange connections.  
**Mounting Orientation:** Vertical.  
**Weight:** 10 lb (4.5 kg).  
**Agency Approvals:** UL.  
**Specific Gravity:** 0.8 minimum. Optional 0.7 minimum.

## MODELS

Model Number	Switch Type
391-WT-4810-C1-80	SPDT Mercury
391-WT-7810-C1-80	SPDT Snap
391-WT-7810HM-C1-80	SPDT Hermetically Sealed Snap