		<b>CONTROL VALVE SPECIFICATION</b>				Customer: Toshiba Energy Systems & Solutions Corporation						
						Reference: Sumitomo Corporation						
						Tanjung Jati B Expansion						
								Coal Fired Steam Power Plant 2x1000MW				
Item	29			Rev.				Style/Model	Diaphragm / 2052			
Quantity	1						Size	3				
Application	STEAM SEAL DIVERTING VALVE (HTR side Run valve)						Actuator	Spring/Adjustor	Dual Spring			
Tag No.	50MAW10AA205, 60MAW10AA205						Air to Actuator	0.0 - 4.5 bar				
Serial No	F002834055, F002834056			<4>			Air Fail to	Valve Close				
Size & Type	DN300 2052 - 7613N						Handwheel	Top Mount				
Body	Valve style	Butterfly					Adjustable Stop	None				
	No. of Port	Single					M'tg. Positon	Right Hand, Style A, Pos 4				
	Rating	ASME CL 150					Positioner	Style/Model	None			
	End Conn	Style	Wafer					Input Signal				
		Finish/Weld Prep	ASME B16.5					Increase Signal				
	Material	Carbon Steel A105		<1>			Bypass/Gauge					
	Push Down To	Valve Open					Air Set	Model	67DFR-SB w/ Gauge			
Flow Direc.	Forward					Set Press.	4.5 bar					
Flow Tend To	--					Mouting Position	Side HW :	--				
Port Size	Full Port						Positioner :	AirSet: 2				
Balance	--					S/V:	1					
Flow Charact.	Approximately EQ%					L/S:	1					
Form	Conventinal					Solenoid Valve ( Q'ty 1 )	Style	3way, Brass, Universal				
Guiding	Bushing						Model	WPT8327B201				
Seat Style	None						De-Energize	Valve Close				
Shut-off Class	ANSI/FCI 70-2 Class I						Elec.Supply	AC220V, 50Hz				
Trim	Material	Trim No.	--					Limit	Style	SPDT×2		
		Cage/Bush.	Steel					Switch	Model	VCL-5101		
	Plug/Disk	WCC		<1>			( Q'ty 2 )	Position	Open×1, Close×1			
	Seat Ring	None						Tag. No.				
	Stem/Shaft	17-4PH SST					Lock-UpValve	Model	None			
Style	None					Trip	Set Press.					
Boss Size	--					Valve	Model	None				
Stem Size	1-1/4 (Class 3)		<4>			Volume Tank	Set Press.					
Bonnet	Packing	Material	Graphite					<b>NOTE</b> 1. SST Name Plate 2. Open type Extension 3. T-Spool Pipe w/WN flange, Carbon Steel, BWE 4N/12A <2> 4. Matching flange, WN, Carbon Steel, DN300, ASME 150RF, BWE 4N/12A <2> 5. 1 set of Line Bolts/Nuts, and Gasket 6. Linkage Design: TSJ-MT-186123 <1> 7. Modification No. : 807K-S200003 <4> 8. Cap nut of UNION shall be installed on valve side <5>				
		Arrangement	Double									
	Lubricator	Steam Seal Nozzle Union, 1 inch, SWE(Note,8)		<5,1>								
Lub. Tapping	Yes, 1/2 NPT		<1>									
Bolting	Bonnet	None										
	Packing	B7/2H										
Valve Rotation	90 deg											
Travel Stopper	None											
Design Temp:	412 deg C		Press:		1.8 bar							
<b>SERVICE CONDITION</b>												
Application:												
Fluid/State	Steam / Vapor											
	Unit											
Shut-off ΔP	bar	1.8										
Rated Coeff.	Cv	7240										
Recovery Coeff.												
Line Size/Sch.	In: DN300, Sch.40 / Out: DN300, Sch.40											
Approved												
T.Matsuo												
Supply Pressure		6.0 - 8.0 bar										
Bench Set		1.07 - 2.52 bar										
Checked	StrokingSpeed (Approx.)	Open to Close	within 20 sec									
		Close to Open	within 20 sec									
Elec.Classification		Indoor										
Inst.Conn.	Pneu.	1/2 NPT		Elec.	1/2 NPT		<6>	<1>	2018/10/10	Rev.1		
Prepared	Pneu. Tubing	PVC covered copper tubing		<5>	2021/7/1	Rev.5	Ord	2018/7/12	171274-04			
	Fitting	37 deg Flare & Sleeve		<4>	2021/3/30	Rev.4	Quot	2018/2/13	SE8443			
Painting	Body	FISHER Sliver		<3>	2019/5/31	Rev.3	Date	No				
	Actuator	FISHER Green		<2>	2018/12/14	Rev.2	Records					
Form:PC-S-2A												
Nippon Fisher Co., Ltd.							LSCN No	--	NF Item	001, 101		

KEY	PART NAME	QTY	REMARKS
1	BODY	1	ASTM A105M STEEL
2	DISC	1	ASTM A216M WCC
3	SHAFT	1	JIS G4303-SUS630
4	TAPER PIN	2	ASTM A564M S17400
5	LANTERN RING	2	R30006
6	PACKING RING	16	DIE MOLDED, GRAPHITE
7	PACKING FOLLOWER	2	JIS G4303-SUS316
8	STUD	4	ASTM A193 B7/ZN PL
9	NUT	4	ASTM A194 2H/ZN PL
10	PIPE NIPPLE/UNION ASSY	2	ASTM A105M/CARBON STEEL
11	OPEN EXTENSION	1	JIS G5502-FCd450
12	LEVER YOKE	1	STL
13	BEARING/SLEEVE	1	STL/ALUM
14	COVER PLATE	1	JIS G4303-SUS403-S
15	MACHINE SCREW	4	18-8 SST
16	CAP SCREW	8	ASTM A193M B8M CL2
17	WASHER	8	CARBON STEEL-PL
18	THRUST COLLAR	2	BRASS OR COPPER-GOLD PL
19	TAPER PIN	2	ASTM A564M S17400
20	PACKING BOX RING	1	316 SST
31	GREASE NIPPLE	1	CARBON STEEL-PL

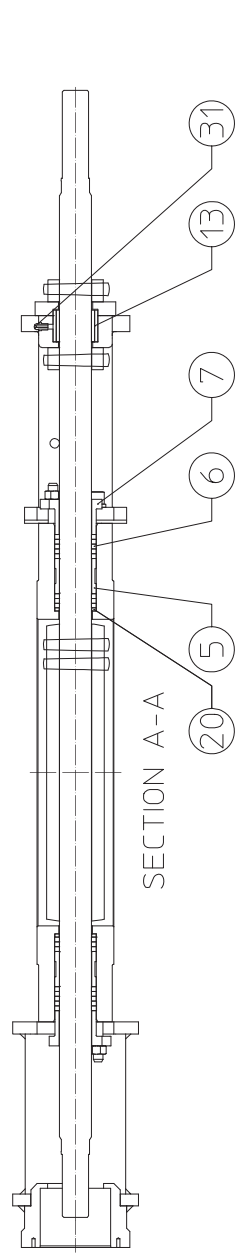
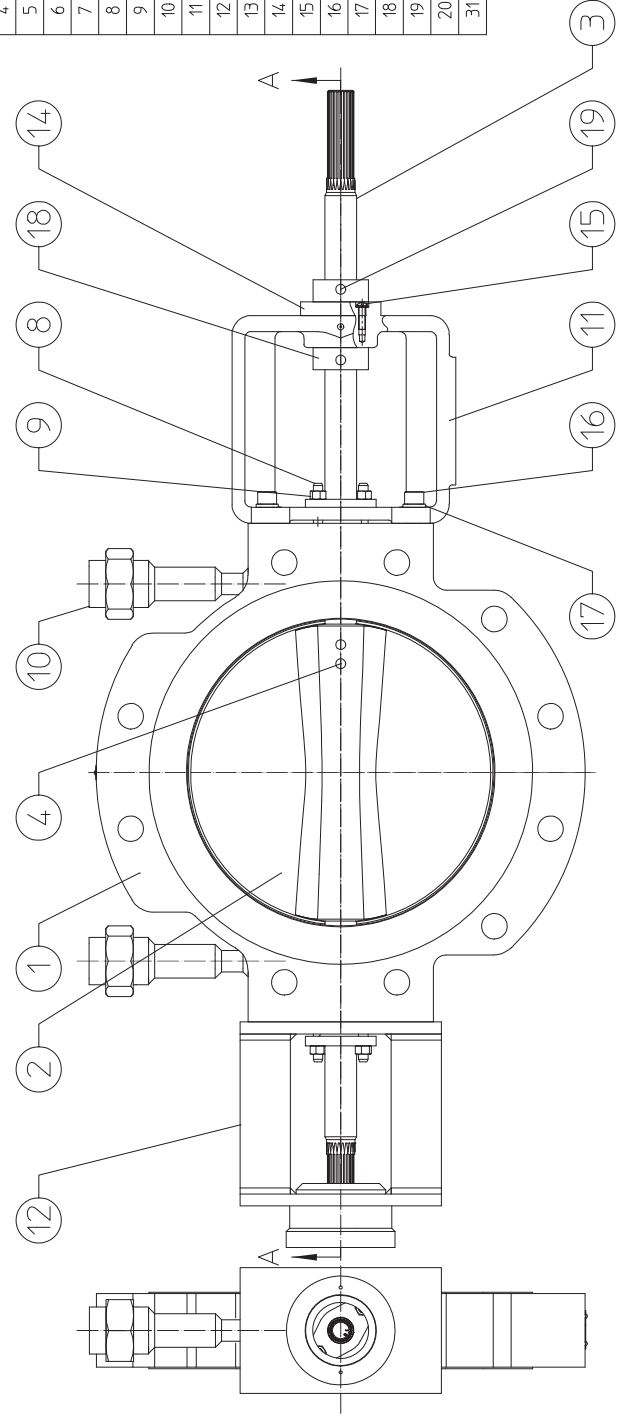

ITEM: 29  
 50MAW10AA205,  
 TAG NO: 60MAW10AA205  
 NF JOB: 171274-04  
 SERIAL: F002834055.056

名称 (TITLE)		VALVE BODY ASSY		型式 (TYPE)	E	7613N (NPS 12)
承認 (APPD)	Jade Kim	12/16/20	△	1-1/4" SHAFT		
監査 (CHKD)	Jade Kim	12/16/20	△	CLASS 3		
製図 (DWN)	HRI	11/30/18	△	図面番号 (DWG.NO.)	25J7067	
承認 (APPD)	Jade Kim	12/16/20	△	図面番号 (DWG.NO.)	REV. B	
監査 (CHKD)	Jade Kim	12/16/20	△	改訂記録 (REVISION)	12/09/20	
製図 (DWN)	HRI	11/30/18	△	Ogura		

NOTE) NPS STANDS FOR "NOMINAL PIPE SIZE" AND DN, "NOMINAL DIAMETER".