

Welding neck G 1

Order number: 52001051
 With 3.1.B material certificate: 52011896
 For flush-mounted Liquicap M installation
 With process connection GWJ
 (seal included in scope of delivery)
 Material: corrosion-resistant steel
 1.4435 (AISI 316L)
 Weight: 0.19 kg
 Replacement seal:
 Silicone O-ring (5-piece set - FDA listed)
 Order number: 52014472

max. 25 bar / max. 150 °C

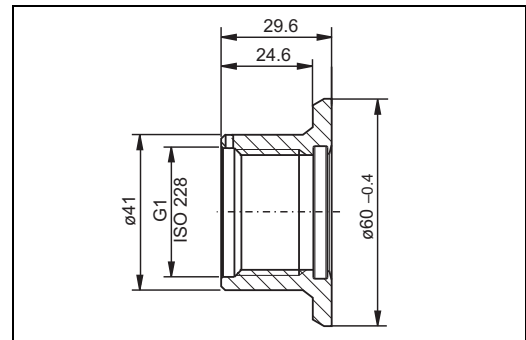

L00-F15xxxx-06-05-xx-xx-020

Spare parts**Electronic insert**

- FEI50H electronic insert
52028260
- FEI57C electronic insert
52028261

Cover for housing without display

- Cover for aluminum housing F13: gray with sealing ring
52002698
- Cover for stainless steel housing F15: with sealing ring
52027000
- Cover for stainless steel housing F15: with clasp and sealing ring
52028268
- Cover for polyester housing F16, flat: gray with sealing ring
52025606
- Cover for aluminum housing F17, flat: with sealing ring
52002699
- Cover for aluminum housing T13, flat: gray with sealing ring/electronics compartment
52006903
- Cover for aluminum housing T13, flat: gray with sealing ring/connection compartment
52007103

Cover for housing with display

- Cover for stainless steel housing F15: with sight glass, clasp and sealing ring
52028267
- Cover for stainless steel housing F15: high, with sight glass and sealing ring
52028269
- Cover for stainless steel housing F15: high, with sight glass, clasp and sealing ring
71005440
- Cover for aluminum housing F13/F17: high, with sight glass and sealing ring
52028270
- Cover for aluminum housing T13: high, with sight glass/electronics compartment for EEx d
52028271
- Cover for polyester housing F16: high, with transparent housing and sealing ring
52025605

Display with holder

- Display with holder for electronic insert FEI50H
52028266