

DVC6000f Series

Key	Description	Part Number	Key	Description	Part Number
Relay					
24	Relay Assembly, includes shroud, relay seal, and mounting screws				
	Standard				
	Double-acting and single-acting direct	38B5786X052			
	Single-acting reverse	38B5786X062			
	Double-acting and single-acting direct (low bleed)	38B5786X072			
	Extreme Temperature option (fluorosilicone elastomers)				
	Double-acting and single-acting direct	38B5786X032			
	Single-acting reverse	38B5786X042			

Terminal Box

4	Terminal Box Cap, Aluminum	38B7714X012
	Stainless Steel	GB0108X0012
34*	O-ring ^(1,8)	
36*	O-ring ^(1,8)	
44	Wire Retainer, pl stl ⁽²⁾ (6 req'd) (not shown)	
58	Set Screw, hex socket, SST ⁽²⁾	
62	Pipe Plug, hex hd, Aluminum	1H5137X0012
	Stainless Steel	1H5137X0032
72	Cap Screw, hex socket, SST ⁽²⁾	
164	Terminal Box Assembly ⁽⁸⁾	
268	FIELDBUS Label	

PWB Assembly



Note

Contact your Emerson Process Management sales office for PWB Assembly FS Numbers.

50*	PWB Assembly	
	Standard Control	
	Fieldbus Diagnostics	
	Advanced Diagnostics	
	Performance Diagnostic	
	Fieldbus Control	
	Fieldbus Diagnostics	
	Advanced Diagnostics	
	Performance Diagnostics	
	Fieldbus Logic	
	Fieldbus Diagnostics	
	Advanced Diagnostics	
	Performance Diagnostics	

Pressure Gauges, Pipe Plugs, or Tire Valve Assemblies

47*	Pressure Gauge, nickel-plated brass case, brass connection		
	Double-acting (3 req'd); Single-acting (2 req'd)		
	PSI/MPa Gauge Scale		
	To 60 PSI, 0.4 MPa		18B7713X042
	To 160 PSI, 1.1 MPa		18B7713X022
	PSI/bar Gauge Scale		
	To 60 PSI, 4 bar		18B7713X032
	To 160 PSI, 11 bar		18B7713X012
66	Pipe Plug, hex hd		
	For Double-acting and single acting direct w/gauges (none req'd)		
	For Single-acting reverse w/gauges (1 req'd)		
	Plated steel		1D829328982
	SST		1D8293X0012
	For all units w/o gauges (3 req'd)		
	Plated steel		1D829328982
	SST		1D8293X0012
67	Tire Valve Assembly (3 req'd)		1N908899012
236	Screen		
	For single-acting direct units only		18B9610X012

Feedback Parts

Common Feedback Parts

80	Cap Screw, hex socket, SST ⁽²⁾	
81	Square Nut, SST ⁽²⁾	
223*	Potentiometer/Bushing Assy	
	Standard	
	For DVC6010f, DVC6010fS, DVC6020f, and DVC6020fS	
	For DVC6030f and DVC6030fS	18B9576X012
	For DVC6015 and DVC6025	17B4030X032
	For DVC6035	19B6834X012
	Extreme Temperature option (fluorosilicone elastomers)	
	For DVC6010f, DVC6010fS, DVC6020f and DVC6020fS	
	For DVC6030f & DVC6030fS	GE01028X012
		GE01027X012
163	Plain Washer, SST ⁽²⁾	

* Recommended spare

1. Available in the Elastomer Spare Parts Kit

2. Available in the Small Hardware Spare Parts Kit

8. Available in the Terminal Box Kit

DVC6000f Series

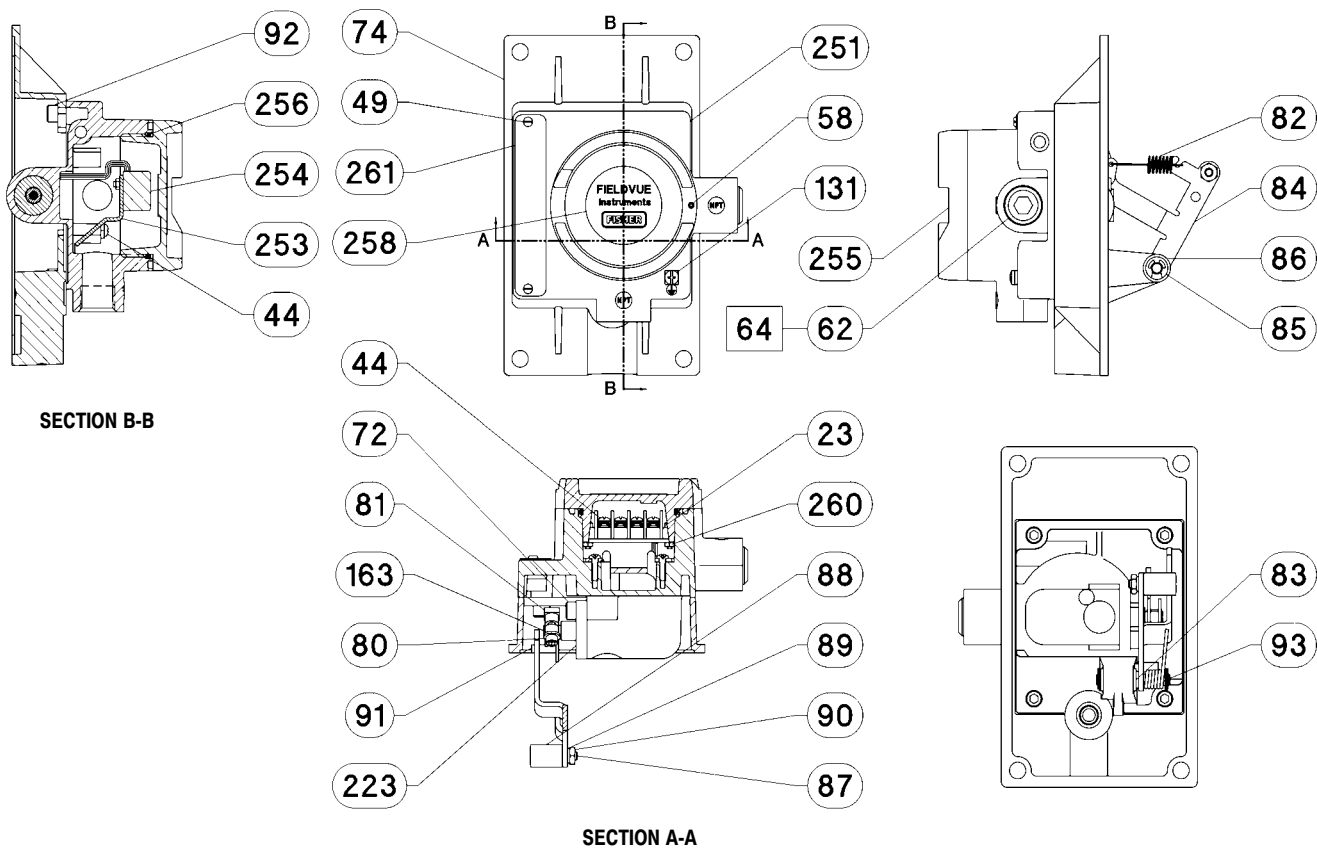

□ APPLY LUB, SEALANT, THREAD LOCK

NOTE:

1. APPLY LUBRICANT KEY 65 TO ALL O-RINGS UNLESS OTHERWISE SPECIFIED

Figure 11-5. Type DVC6025 Digital Valve Controller Assembly