

2. Rotate the ball to the closed position.
3. Follow one of the procedures below:
 - When viewed from the valve body inlet, the ball is in the proper position when both V-notches of the ball are centered between the machined diameter of the ledge that supports the seal.
 - If the ball has a spot machined on the top, align that spot to the exact center of the seal cavity.
4. Adjust the actuator linkage as described in the appropriate actuator instruction manual until the condition described in step 3 exists. A line is stamped on the actuator end of the drive shaft (see figure 23) to indicate the ball position.

⚠ WARNING

Use only genuine Fisher replacement parts. Components that are not supplied by Emerson Process Management should not, under any circumstances, be used in any Fisher valve, because they will void your warranty, might adversely affect the performance of the valve, and could give rise to personal injury and property damage.

Non-Series B Design Parts (figure 31)

Note

Part numbers are shown for recommended spares only. For part numbers not shown, contact your Emerson Process Management sales office.

Key	Description	Part Number
2	Ball	
2	Ball with attenuator (RH mtg in Common parts section)	
6	Drive Shaft	
9	Follower Shaft	
10*	Bearing (2 req'd)	
	PEEK	
	NPS 3 and 4	14B3354X012
	NPS 6	14B3355X012

Key	Description	Part Number
	NPS 8 and 10	14B3356X012
	NPS 12	14B3357X012
	S44004 (440C SST)	
	NPS 2	23B6682X022
	NPS 3 and 4	14A5698X012
	NPS 6	14A4618X012
	NPS 8 and 10	14A5699X012
	NPS 12	14A6549X012
	R30016 (alloy 6B)	
	NPS 3 and 4	14A6546X012
	NPS 6	14A6547X012
	NPS 8 and 10	14A6548X012
	NPS 12	14A6550X012
	Silver-plated R30016 (alloy 6B)	
	NPS 3 and 4	14A6537X012
	NPS 6	14A2498X012
	NPS 8 and 10	14A6538X012
	NPS 12	14A6539X012
	Carbon-filled PTFE with N10276 sleeve	
	NPS 3 and 4	12B5944X012
	NPS 6	12B5945X012
	Glass-filled PTFE with N10276 sleeve	
	NPS 3 and 4	12B5944X042
	NPS 6	12B5945X042

* Recommended spare parts

Figure 31. Fisher V150 and V300 Non-Series B Valve Assembly (NPS 3- 12)
 (Details are typical for V200 Valves except V200 does not have flanges)

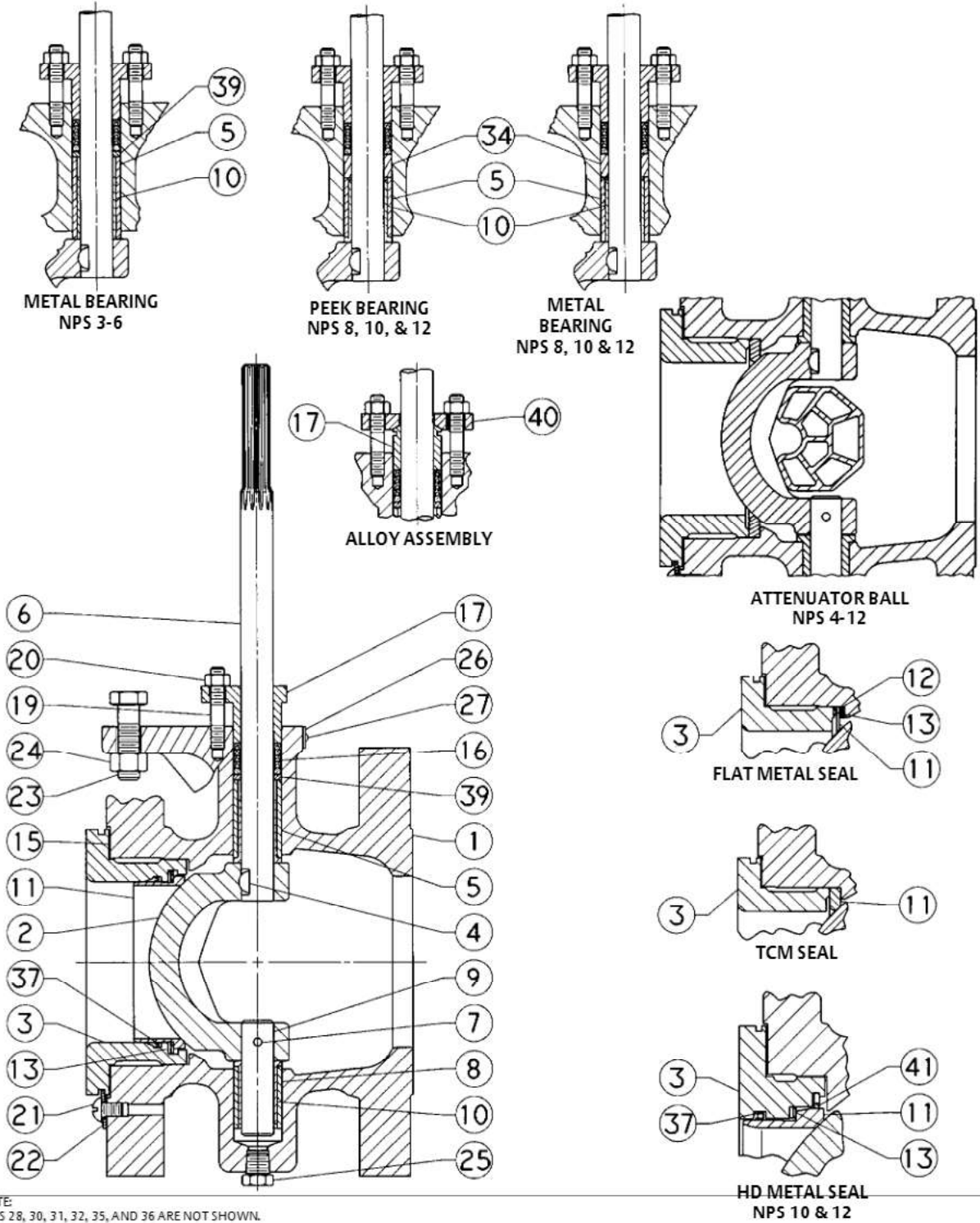

4284652-C

NOTE:
 KEYS 28, 30, 31, 32, 35, AND 36 ARE NOT SHOWN.