

TIMKEN**The Timken Company**

4500 Mt Pleasant St. NW

N. Canton, OH 44720

Phone: (234) 262-3000

E-Mail: CustomerCAD@timken.com • Web site: www.timken.com

Part Number 3311 AJ/C3, Timken® Double Row Angular Contact Ball Bearings (3200, 3300)

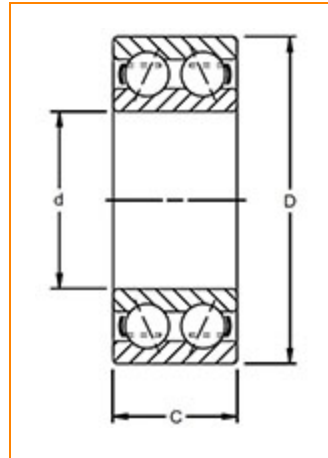

[Dimensions](#) | [Specifications](#) | [Basic Load Ratings](#) | [Abutment and Fillet Dimensions](#)

Dimensions

d - Bore	55.00 mm 2.1654 in
D - Outer Diameter	120.00 mm 4.7244 in
C - Ring Width	49.2 mm 1.9370 in
Contact Angle	30 °
do - Ball Diameter	19.050 mm 1 -1/4 in

Specifications

Features	Open
-----------------	------

Ball Type	STEEL
Cage Type	Pressed
Cage Material	Steel
Bearing Weight	2.42 Kg 5.336 lb
Design Units	METRIC

Basic Load Ratings

C0 - Static Radial Rating	71000 N 15958 lbf
C1 ISO - Dynamic Radial Rating	92200 N 20723 lbf

Abutment and Fillet Dimensions

R - Inner Ring "To Clear" Radius ¹	2 mm 0.079 in
r - Outer Ring "To Clear" Radius ²	2 mm 0.079 in
da - Inner Ring Backing Diameter	65.00 mm 2.559 in
Da - Outer Ring Backing Diameter	110.00 mm 4.3310 in

¹ Maximum housing fillet radius that bearing corners will clear.

² Maximum shaft fillet radius that bearing corners will clear.

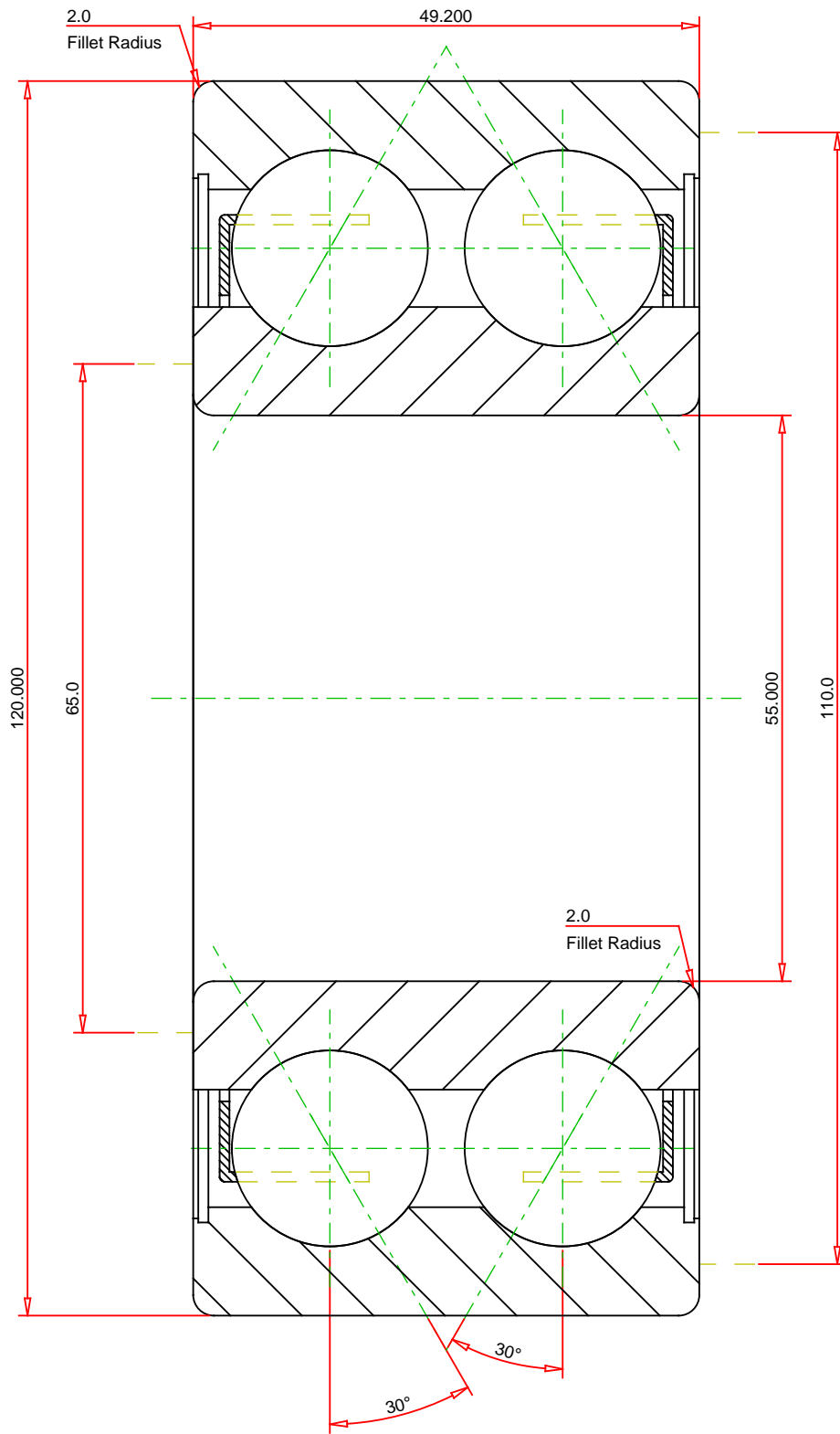

METRIC UNITS

Number of Balls Per Row 16
 Bearing Weight 2.420 kg

TIMKEN®

3311 AJ/C3
 Timken® Double Row Angular Contact Ball Bearings
 (3200, 3300)

THE TIMKEN COMPANY
 NORTH CANTON, OHIO USA

Dynamic Load Rating 92200 N
 Static Load Rating 71000 N

Every reasonable effort has been made to ensure the accuracy of the information contained in this writing, but no liability is accepted for errors, omissions or for any other reason.

FOR DISCUSSION ONLY