

Daniel™ Orifice Plates and Plate Sealing Units

Differential Pressure Flow Meters

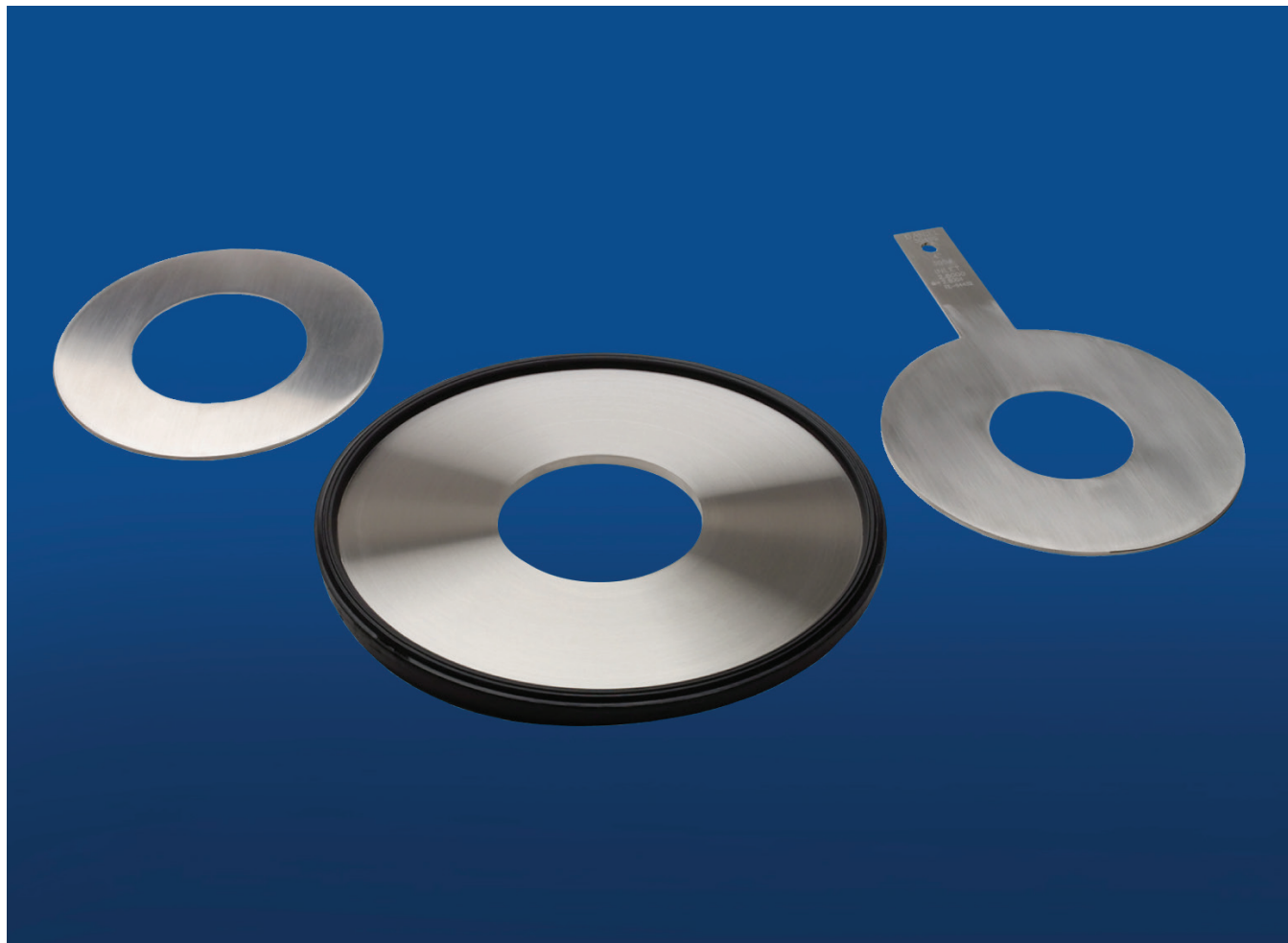

DANIEL™

EMERSON™

Daniel Orifice Plates and Plate Sealing Units

Quality Beyond Compare

Exceptional performance and superior durability are the hallmarks of Daniel Orifice Plates and Plate Seals. These simple yet effective differential pressure measurement solutions have been serving the oil and gas industry for more than 85 years and remain one of the most widely used technologies. Today, additional plate and seal options are available to ensure measurement accuracy and improved longevity in challenging measurement conditions.

Standard Daniel plate offerings include universal and dual vulcanized seal (DVS) plates for use with Daniel Orifice Fittings. Standard paddle-type plates are also available for use in Daniel Orifice Flange Unions. Plates can be ordered in standard stainless steel or optional Monel®, Inconel® and other exotic materials to improve durability. To prevent leakage, a variety of plate seal materials are available for universal plates, including nitrile (NBR) and PTFE, that help improve performance and durability in certain applications.

Every Daniel orifice plate is manufactured to ensure compliance with industry standards as well as to meet specific application requirements. For optimal performance, the plate bore must be properly sized and beveled. Standard plates have a 45° bevel on the periphery of the bore hole which offers optimal conditions for clean, dry gas or low viscosity liquids. For dirty gas or other challenging fluid types, special plate designs help improve measurement accuracy, including plates with segmental, quarter-round, and counter bores. In addition, the nominal plate bore of every Daniel Orifice Plate is inspected prior to shipment using a Coordinate Measurement Machine (CMM) to validate its compliance with AGA 3/API 14.3 and/or ISO 5167. From material selection to final packaging, every step of plate production is controlled and documented.

Table 1: Plate Tolerance (specific tolerances that apply to most Daniel orifice plates)	
Edges	Square and sharp, and will not reflect a beam of light when viewed without magnification
Finish	≤ 30 micro-inch roughness
Flatness	Flat within 0.010-in, per inch of dam height (where dam height equals the pipe diameter minus the orifice diameter, divided by 2)
Bore	Plate bore tolerances comply with AGA 3/API 14.3, ASME, ISO, ISA, etc. or per customer requirement

Typical Applications

- Custody transfer of oil and gas
- Allocation Measurement

Application Sites

- Pipelines including transmission and distribution
- Offshore / onshore production
- Gas processing plants
- Large industrial sites

Features and Benefits

- Precision machining along with superior quality control heighten measurement accuracy and reliability
- Highly accurate flow measurement can be determined without the need for calibration
- Simple to operate and easy to troubleshoot in the field
- No moving parts ensure minimal maintenance
- Low cost of ownership

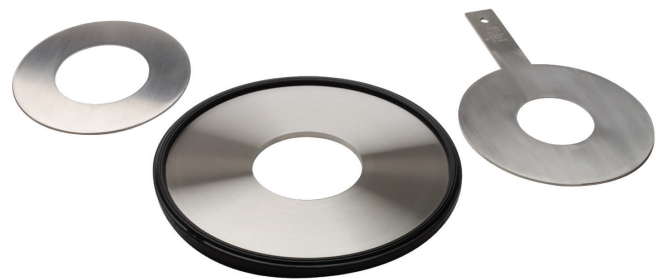

Figure 1: Daniel orifice plates

Daniel plates ensure accurate measurement and comply with AGA3/API 14.3, ISO or per customer requirements where applicable.

Standard Specifications

Please consult a Daniel technical specialist if application requirements are outside of the listed specifications. Other product and material offerings may be available. Please consult factory.

Plate Specifications

Types of Orifice Plates

- Model 500 Universal Plate
- Model 510 Universal 3DVS Plate
- Model 520 Paddle-Type Plate
- Other (consult factory)

Types of Orifice Plate Holders For Ring Type Flange Unions

- Model 560 Holder with integral plate
- Model 590 Holder with removable plate

Bore Type

- Concentric (Bore and bevel)⁽¹⁾
- Concentric (Bore and no bevel)
- Bore and counter bore
- Segmental
- Eccentric
- Quadrant round
- Blank
- Other (consult factory)

Plate Thickness

- 3.2 mm to 12.7 mm (0.125-in to .5-in)⁽²⁾
- Other (consult factory)

Plate Finish

- Standard: ≤ 30 micro-inch roughness
- Optional: Serrated face 125 to 250 RMS
- Other (consult factory)

Measurement Standard

- AGA 3/API 14.3
- ISO 5167
- Other (consult factory)

Mechanical Ratings

Line Sizes

- DN10 to DN900 (0.25-in to 24-in)⁽³⁾
- Other (consult factory for larger sizes)

Pressure Rating

- PN25 to PN200 (ANSI 150 to 2500)

NACE and PED Compliance

- Consult factory

Material Specifications

Plate and Plate Holder

- 316 SS
- Optional: 400, C-276 and other materials

Plate Seals

- NBR (Nitrile)
- HNBR
- FKM
- Optional: PTFE
- Other (consult factory)

Table 2: Daniel Plate Identification (information stamped on each Daniel plate by model number)				
Orifice Plate Identification	Model 500 Universal Plate	Model 510 Universal DVS Plate	Model 520 Paddle-Type Plate	
Line Items	Daniel	•	•	•
	Nominal Line Size	•	•	•
	Material Type	•	•	•
	Outlet	•	•	
	Inlet			•
	Heat Number	•	•	•
	Bonding PO #		•	
	Country of Origin	•	•	•
	Bore as specified on order or "Blank" for non-bored	•	•	•
	Bore corrected to 68 °F	•	•	•
	Tag Number	•	•	•
	Reference Number/Part Number (Supplier Only)	•	•	•
	ANSI Rating			•

(1) Bevel as needed per the standard

(2) Refer to the weights and dimensions information to confirm the thickness by plate type and size.

(3) Line size varies by model.

Orifice Plate Options





Please consult a Daniel technical specialist if application requirements are outside of the listed specifications. Other product and material offerings may be available.

Accuracy

- Discharge coefficient uncertainty ± 0.5 to 0.75%
- Orifice plates are one part of a flow measurement system. Daniel orifice plates are manufactured to meet the requirements of industry standards but must be installed and maintained per the standards. Discharge coefficient uncertainties when used correctly will be according to those published in the standards API 14.3, AGA #3, and ISO 5167.

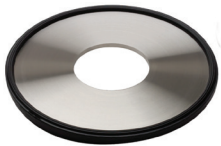



Orifice Bore Calculation

Accurate calculation of the orifice plate bore is essential to measurement accuracy. To ensure precise calculation and manufacturing, one of our technical experts will provide the orifice bore calculation form that will need to be completed by the customer.

Table 3: Orifice Plates	
Model 500	Line Sizes 2 to 24 inch
	Universal orifice plates originated by Daniel are the standard used in many industries. When combined with Daniel sealing units, the universal style is used in Daniel orifice fittings. The universal size is the most economical style of orifice plate because of low initial cost, small storage space required, and the elimination of stocking plates for various pressure ratings.
Model 510	Line Sizes 12 to 24 inch
	For larger sized fittings, these universal plates are sealed with bonded rubber seals. The permanently bonded rubber creates a secure seal around the plate. Plates with damaged seals can be returned to the factory for repair.
Model 520	Line Sizes 1/2 to 24 inch
	Daniel paddle type orifice plates are used with raised face orifice flange unions. These are the most widely used flow measurement elements in the world. The plate is machined to match line and flange rating. The handle provides identification and information while installed.
Model 560	Line Sizes 1/2 to 24 inch
	Orifice plate holders provide a paddle style orifice for RTJ flange unions. The 560 is an integral plate holder made with a non-removable orifice plate to eliminate bypass leakage around the plate. RTJ plate holders provide an excellent self-centering installation that does not rely on flange bolting for location.
Model 590	Line Sizes 2 to 24 inch
	590 plate holders are used in conjunction with 500 plates for use in RTJ flange unions. Plates can be economically changed without replacement of the plate holder. Holding screws are used to secure the plate to the holder. A gasket is provided as a seal between the plate and holder. Orifice plates are not included and must be ordered separately.

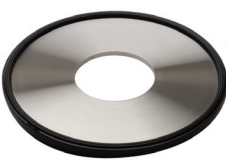
Orifice Plate Sealing Units Options

Five types of sealing units are available for use with the Daniel Catalog No. 500 orifice plates.

Table 4: Orifice Plate Sealing Units			
DSC Dual Seal	Line Sizes 2 to 16 inch		
	The Daniel Dual Seal is the most simple and practical orifice plate sealing device for normal flowing streams. It is precision molded and provides four metal-to-metal sealing surfaces 360° around the plate. The units positively seal against both outer faces of the plate and against both seat faces of the orifice fitting to prevent leakage. The DSC is interchangeable with Daniel TSC and MSC seal units.		
	Specifications		
	Materials 70-80 shore nitrile synthetic rubber FKM fluoroelastomer	Maximum Working Pressure 600 ANSI	Process Temperature Limits -20 to +275°F
DVS Dual Seal	Line Sizes 12 to 24 inch		
	In larger sizes, rubber is bonded directly to the outer edge of the orifice plate. If damaged, the DVS seal and plate may be returned to the factory for revulcanizing. Universal plates with bonded seal are Model 510.		
	Specifications		
	Materials 80-90 shore nitrile synthetic rubber FKM fluoroelastomer	Maximum Working Pressure 600 ANSI	Process Temperature Limits -20 to +275°F
SSR Snap Seal Ring	Line Sizes 2 to 24 inch		
	The Daniel Snap Seal Ring is a removable orifice plate holder designed for use in services where elastomer seals are not recommended due to swelling or chemical compatibility. The Snap Seal Ring unit consists of two symmetrical metal rings, each one having an O-ring on both sides for a positive seal on the plate side and the fitting side of the ring. These rings center and secure the orifice plate between them. The assembled unit provides a full 360° rubber to metal seal around both sides, even in the absence of any pressure differential. No special tools are required for assembly or disassembly.		
	Specifications		
	Materials Zinc plated carbon steel 316 stainless steel Duplex	Maximum Working Pressure 2500 ANSI	Process Temperature Limits -20 to +275°F (Standard O-rings - NBR, HNBR, FKM) -67 to +437°F (Speciality O-rings - Consult factory)
TSC PTFE Seal	Line Sizes 2 to 24 inch		
	The Daniel PTFE seal is a superior orifice plate sealing unit for difficult, corrosive flows and for higher temperatures. The TSC has proven effective in such flows as dilute sulfuric acid, fuming nitric acid, hydrazine and other unusual fluids. The two piece unit consists of an inlet ring which fits around the plate outer diameter, and a downstream ring fitted with metal clips for assembling the unit. A special lip on this ring plus an annular groove provides compression to effectively seal off the plate. The TSC unit can be assembled or taken apart by hand.		
	Specifications		
	Materials PTFE Size 10 inch & larger have graphite added for lubricity and ease of movement.	Maximum Working Pressure 2500 ANSI	Process Temperature Limits -56 to +275°F max
MSC Metal Seal	Line Sizes 2 to 12 inch		
	The Daniel Metal Seal is a stainless or zinc plated carbon steel clip ring assembly recommended for high pressures and for temperatures up to +275°F. The assembly consists of an upstream and downstream ring. The MSC seal unit can be assembled or taken apart by hand. Product not intended for custody transfer.		
	Specifications		
	Materials Zinc plated carbon steel 316 stainless steel	Maximum Working Pressure 2500 ANSI	Process Temperature Limits -20 to +275°F

Orifice Plate Bore Options

A variety of specialized orifice plate bores are available to meet application requirements. Please consult with a Daniel technical specialist to confirm the most suitable bore for your application.

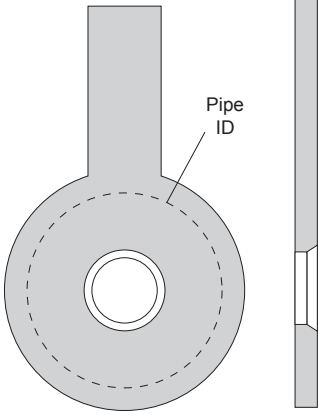
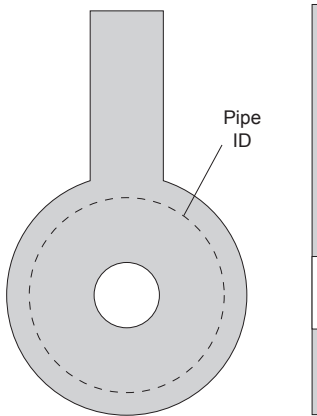
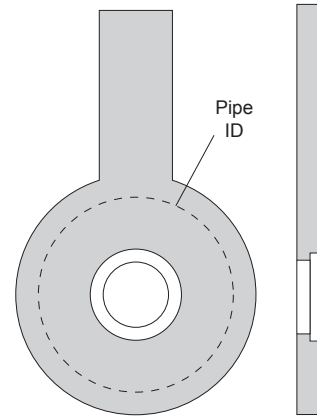
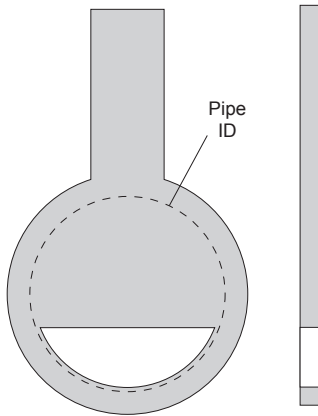
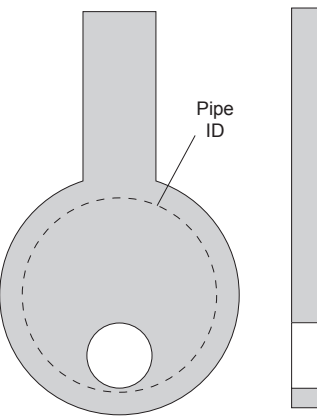
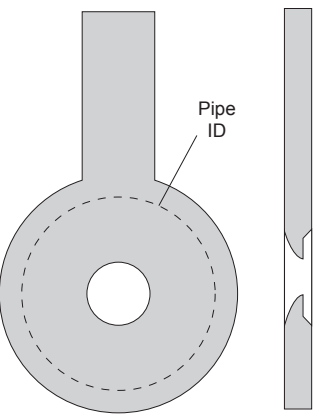
Bore and Bevel (Concentric)	Bore without Bevel (Concentric)	Bore and Counterbore
 <p>The bore and bevel is the standard method of limiting the plate edge thickness. The bevel is machined on a 45° angle to the desired edge thickness. Unless otherwise specified the plates will be beveled to leave an edge thickness 1/50 of the line ID or 1/8 of the orifice bore, whichever is smaller.</p>	 <p>For certain combinations of line size and plate thickness, it is not necessary to have a bevel to meet plate edge thickness requirements. In this case, the bore is drilled straight through the entire thickness of the plate. This bore is also used for bi-directional measurement and restriction orifices.</p>	 <p>The bore and counterbore is a special method to limit the plate edge thickness. Instead of beveling at the normal 45° angle, the plate is counterbored to the desired edge thickness.</p>
Segmental Bore	Eccentric Bore	Quarter Round Bore (Quadrant Edge)
 <p>Segmental bore orifice plates are provided for measurements to allow solids, liquids, and bubbles to pass through the bore. The circular portion of the bore is manufactured to be tangent to 98% of the pipe ID. Several industries use this type of bore, including sewage treatment, steel, chemical, water conditioning, paper and petrochemical.</p>	 <p>Eccentrically-bored plates position the bore off-center as opposed to concentrically. The bore of the eccentric orifice is generally inscribed in a circle that is 98% of the pipe ID, enabling solids or slurries to pass through the bore. Eccentric orifice plates are used in many industries, including heavy and light chemicals, steel, paper, atomic and petrochemical.</p>	 <p>The quarter round, or quadrant bore, offers a rounded inlet edge. The radius of the quarter round bore is a function of the orifice-to-pipe ratio with thickness at the throat equal to the radius. Overall plate thickness is frequently greater than the thickness of standard plates. This bore is specifically designed for fluids of high viscosity, including heavy crudes, syrups and slurries. Quarter round bores are recommended for viscous fluids with Reynolds numbers below 10,000.</p>

Weights and Dimensions

The Plate Dimension diagram (Figure 2) demonstrates the plate component measurements that correspond to A and B in Tables 5A and 5B below. All weights are based on the dimensions provided for blank plates.

Universal Orifice Plates: Model 500

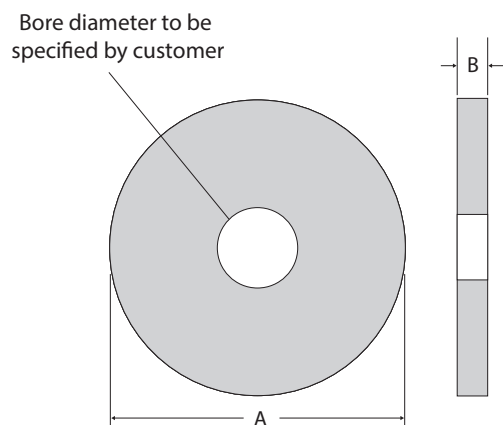

Figure 2: Plate Dimension Diagram for Universal Orifice Plates

Table 5A: Weights and Dimensional Data (Metric Units)																
Universal Orifice Plate (Model 500)																
Line Size (DN)	20	25	40	50	60	80	100	150	200	250	300	350	400	450	500	600
Blank Weight (kg)	0.03	0.03	0.05	0.08	0.11	0.15	0.25	0.54	1.84	2.91	4.36	5.40	10.29	13.03	15.98	30.25
A: Plate OD (mm)	28.6	33.3	50.8	61.9	71.4	87.3	87.3	163.5	214.3	271.5	319.9	355.6	406.4	457.2	508	609.6
B: Plate Thickness	3.2	3.2	3.2	3.2	3.2	3.2	3.2	3.2	6.4	6.4	6.4	6.4	9.5	9.5	9.5	12.7

Table 5B: Weights and Dimensional Data (US Customary Units)																
Universal Orifice Plate (Model 500)																
Line Size (in)	0.75	1	1.5	2	2.5	3	4	6	8	10	12	14	16	18	20	24
Blank Weight (lb)	0.06	0.06	0.11	0.17	0.25	0.34	0.55	1.18	4.06	6.41	9.61	11.91	22.69	28.72	35.24	66.7
A: Plate OD (in)	1.125	1.312	2	2.437	2.812	3.437	4.406	6.437	8.437	10.687	12.593	14	16	18	20	24
B: Plate Thickness (in)	0.125	0.125	0.125	0.125	0.125	0.125	0.125	0.125	0.25	0.25	0.25	0.25	0.375	0.375	0.375	0.5

Weights and Dimensions

The Plate Dimension diagram (Figure 3) demonstrates the plate component measurements that correspond to A and B in Tables 6A and 6B below. All weights are based on the dimensions provided for blank plates.

Universal 3DVS Orifice Plates: Model 510

DN300 (12-in) and larger Universal orifice plates may include a synthetic rubber sealing unit (i.e. DVS) that is bonded to both sides of the plate, providing a non-metallic seal in the orifice fitting body seat. Dimension A in the chart above includes this seal. Plates with the 3DVS seal are standard for most applications in line sizes DN300 (12-in) and larger. Other types of seals are available for use with Series 500 plates in these line sizes.

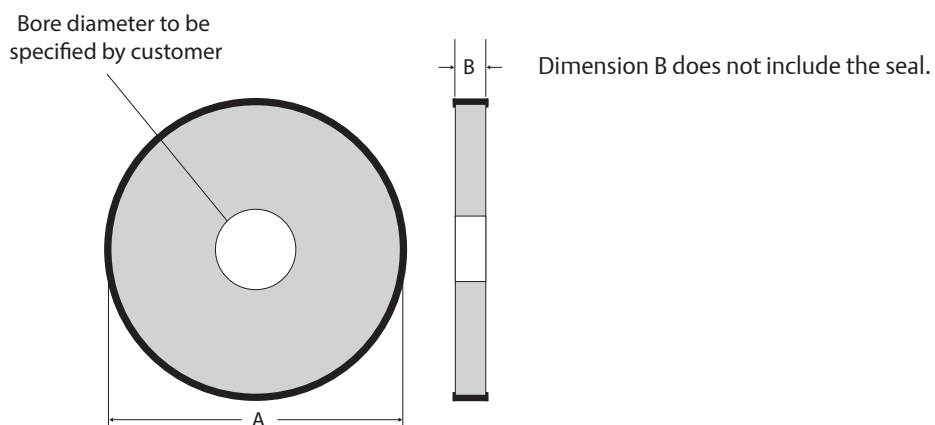

Figure 3: Plate Dimension Diagram for Universal 3DVS Orifice Plates

Table 6A: Weights and Dimensional Data (Metric Units)						
Universal 3DVS Orifice Plate (Model 510)						
Line Size (DN)	300	350	400	450	500	600
Blank Weight (kg)	4.4	5.4	10.3	13.1	16.0	30.3
A: Plate O.D. (mm)	332.2	369.9	420.7	471.5	522.3	622.3
B: Plate Thickness (mm)	6.4	6.4	9.5	9.5	9.5	12.7

Table 6B: Weights and Dimensional Data (US Customary Units)						
Universal 3DVS Orifice Plate (Model 510)						
Line Size (in)	12	14	16	18	20	24
Blank Weight (lb)	9.61	11.91	22.69	28.72	35.24	66.7
A: Plate O.D. (in)	13.079	14.563	16.563	18.563	20.563	24.5
B: Plate Thickness (in)	0.25	0.25	0.375	0.375	0.375	0.5

Weights and Dimensions

The Plate Dimension diagram (Figure 4) demonstrates the plate component measurements that correspond to A, B, C and D in Table 8A below and Table 8B on page 9. All weights are based on the dimensions provided.

Paddle-Type Orifice Plates: Model 520

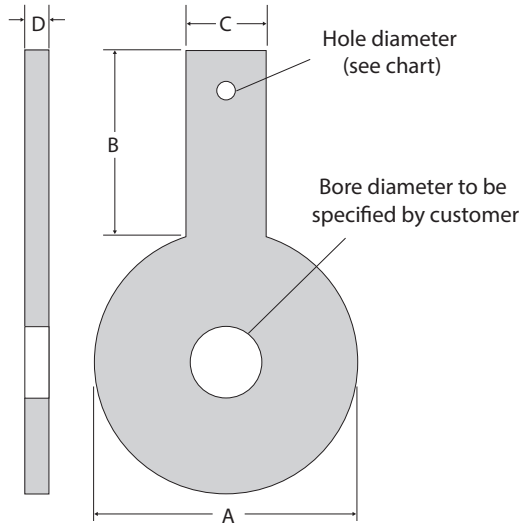

Table 7A: Hole Diameter by Plate Size (Metric Units)	
Plate Size	Hole Diameter
DN15 to DN50	6.4 mm
DN60 to DN600	9.5 mm

Table 7B: Hole Diameter by Plate Size (US Customary Units)	
Plate Size	Hole Diameter
0.5-in to 2-in	0.25 inch
2.5-in to 24-in	0.375 inch

Figure 4: Plate Dimension Diagram for Paddle Type Orifice Plates

Table 8A: Weights and Dimensional Data (Metric Units)																			
Paddle-Type Orifice Plate (Model 520)																			
Line Size (DN)		15	20	25	30	40	50	60	75	100	150	200	250	300	350	400	450	500	600
PN20	Blank Weight (kg)	0.04	0.07	0.14	CF	0.2	0.28	CF	0.42	0.66	1.06	3.27	4.7	6.77	8.17	15.89	16.15	22.14	41.25
	A: Plate OD (mm)	47.6	57.15	66.7	76.2	85.7	104.8	123.8	136.5	174.6	222.3	279.4	339.7	409.6	450.9	514.4	546.1	603.3	714.4
	B: Handle Length (mm)	101.6	101.6	101.6	101.6	101.6	101.6	101.6	101.6	101.6	127	127	152.4	152.4	152.4	152.4	152.4	152.4	152.4
	C: Handle Width (mm)	25.4	25.4	25.4	25.0	25.4	25.40	31.8	31.8	31.8	38.1	38.1	38.1	38.1	38.1	38.1	38.1	38.1	38.1
	D: Plate Thickness (mm)	3.2	3.2	3.2	3.2	3.2	3.2	3.2	3.2	3.2	3.2	6.4	6.4	6.4	6.4	9.5	9.5	9.5	12.7
PN50	Blank Weight (kg)	0.05	0.1	0.16	CF	0.24	0.3	CF	0.5	0.71	1.33	3.96	5.32	7.18	9.46	21.49	25.77	CF	48.14
	A: Plate OD (mm)	54	66.7	73	82.6	95.3	111.1	130.2	149.2	181	250.8	308	362	422.3	485.8	539.8	593.7	650.9	771.5
	B: Handle Length (mm)	101.6	101.6	101.6	101.6	101.6	101.6	101.6	101.6	101.6	127	127	152.4	152.4	152.4	152.4	152.4	152.4	152.4
	C: Handle Width (mm)	25.4	25.4	25.4	25.4	25.4	25.4	31.8	31.8	31.8	38.1	38.1	38.1	38.1	38.1	38.1	38.1	38.1	38.1
	D: Plate Thickness	3.2	3.2	3.2	3.2	3.2	3.2	3.2	3.2	3.2	3.2	6.4	6.4	6.4	6.4	9.5	9.5	9.5	12.7
PN100	Blank Weight (kg)	0.05	0.1	0.16	CF	0.24	0.3	CF	0.5	0.81	1.51	4.29	6.46	8.4	9.7	19.13	22.66	28.07	50.13
	A: Plate OD (mm)	54	66.7	73	82.6	95.3	111.1	130.2	149.2	193.7	266.7	320.7	400.1	457.2	492.1	565.2	609.6	679.5	787.4
	B: Handle Length (mm)	101.6	101.6	101.6	101.6	101.6	101.6	101.6	101.6	101.6	127	127	152.4	152.4	152.4	152.4	152.4	152.4	152.4
	C: Handle Width (mm)	25.4	25.4	25.4	25.4	25.4	25.4	31.8	31.8	31.8	38.1	38.1	38.1	38.1	38.1	38.1	38.1	38.1	38.1
	D: Plate Thickness (mm)	3.2	3.2	3.2	3.2	3.2	3.2	3.2	3.2	3.2	3.2	6.4	6.4	6.4	6.4	9.5	9.5	9.5	12.7
PN150	Blank Weight (kg)	0.05	0.1	0.19	CF	0.25	0.47	CF	0.62	0.91	1.76	5.34	7.62	9.96	10.85	19.78	24.58	29.42	56.79
	A: Plate OD (mm)	63.5	69.9	79.4	88.9	98.4	142.9	165.1	168.3	206.4	288.9	358.8	435	498.5	520.7	574.7	635	695.3	835.03
	B: Handle Length (mm)	101.6	101.6	101.6	101.6	101.6	101.6	101.6	101.6	101.6	127	127	152.4	152.4	152.4	152.4	152.4	152.4	152.4
	C: Handle Width (mm)	25.4	25.4	25.4	25.4	25.4	25.4	31.8	31.8	31.8	38.1	38.1	38.1	38.1	38.1	38.1	38.1	38.1	38.1
	D: Plate Thickness (mm)	3.2	3.2	3.2	3.2	3.2	3.2	3.2	3.2	3.2	3.2	6.4	6.4	6.4	6.4	9.5	9.5	9.5	12.7
PN250	Blank Weight (kg)	CF	CF	CF	CF	CF	CF	CF	CF	CF	CF	CF	CF	CF	CF	CF	CF	CF	CF
	A: Plate OD (mm)	63.5	69.9	79.4	88.9	98.4	142.9	165.1	174.7	209.6	282.6	352.4	435	520.7	577.9	641.4	701.7	752.5	901.7
	B: Handle Length (mm)	101.6	101.6	101.6	101.6	101.6	101.6	101.6	101.6	101.6	127	127	152.4	152.4	152.4	152.4	152.4	152.4	152.4
	C: Handle Width (mm)	25.4	25.4	25.4	25.4	25.4	25.4	31.8	31.8	31.8	38.1	38.1	38.1	38.1	38.1	38.1	38.1	38.1	38.1
	D: Plate Thickness (mm)	3.2	3.2	3.2	3.2	3.2	3.2	3.2	3.2	3.2	3.2	6.4	6.4	6.4	6.4	9.5	9.5	9.5	12.7
PN400	Blank Weight (kg)	CF	CF	CF	CF	CF	CF	CF	CF	CF	CF	CF	CF	CF	CF	CF	CF	CF	CF
	A: Plate OD (mm)	69.9	76.2	85.7	104.8	117.5	146.1	168.3	196.9	235	317.5	387.4	476.3	549.3	CF	CF	CF	CF	CF
	B: Handle Length (mm)	101.6	101.6	101.6	101.6	101.6	101.6	101.6	101.6	101.6	127	127	152.4	152.4	152.4	152.4	152.4	152.4	152.4
	C: Handle Width (mm)	25.4	25.4	25.4	25.4	25.4	25.4	31.8	31.8	31.8	38.1	38.1	38.1	38.1	38.1	38.1	38.1	38.1	38.1
	D: Plate Thickness (mm)	3.2	3.2	3.2	3.2	3.2	3.2	3.2	3.2	3.2	3.2	6.4	6.4	6.4	6.4	9.5	9.5	9.5	12.7

Table 8B: Weights and Dimensional Data (US Customary Units)

Paddle-Type Orifice Plate (Model 520)																				
Line Size (in)		0.50	0.75	1.00	1.25	1.50	2	2.5	3	4	6	8	10	12	14	16	18	20	24	
ANSI 150	Blank Weight (lb)	0.09	0.16	0.31	CF	0.43	0.59	CF	0.93	1.46	2.34	7.22	10.37	14.92	18.01	35.03	35.60	48.81	90.94	
	A: Plate OD (in)	1.875	2.25	2.625	3	3.375	4.125	4.875	5.375	6.875	8.75	11	13.375	16.125	17.75	20.25	21.5	23.750	28.125	
	B: Handle Length (in)	4	4	4	4	4	6	6	6	6	6	6	6	6	6	6	6	6	6	6
	C: Handle Width (in)	1	1	1	1	1	1	1.25	1.25	1.25	1.5	1.5	1.5	1.5	1.50	1.5	1.5	1.5	1.5	1.5
	D: Plate Thickness (in)	0.125	0.125	0.125	0.125	0.125	0.125	0.125	0.125	0.125	0.125	0.25	0.25	0.25	0.25	0.375	0.375	0.375	0.375	0.5
ANSI 300	Blank Weight (lb)	0.12	0.21	0.36	CF	0.52	0.66	CF	1.1	1.57	2.94	8.72	11.73	15.84	20.86	47.37	56.81	CF	106.12	
	A: Plate OD (in)	2.125	2.625	2.875	3.25	3.75	4.375	5.125	5.875	7.125	9.875	12.125	14.25	16.625	19.125	21.25	23.375	25.625	30.375	
	B: Handle Length (in)	4	4	4	4	4	6	6	6	6	6	6	6	6	6	6	6	6	6	6
	C: Handle Width (in)	1	1	1	1	1	1	1.25	1.25	1.25	1.5	1.5	1.5	1.5	1.5	1.5	1.5	1.5	1.5	1.5
	D: Plate Thickness (in)	0.125	0.125	0.125	0.125	0.125	0.125	0.125	0.125	0.125	0.125	0.25	0.25	0.25	0.25	0.375	0.375	0.375	0.375	0.5
ANSI 600	Blank Weight (lb)	0.12	0.21	0.36	CF	0.52	0.66	CF	1.1	1.78	3.33	9.46	14.25	18.52	21.4	42.18	49.95	61.88	110.52	
	A: Plate OD (in)	2.125	2.625	2.875	3.25	3.75	4.375	5.125	5.875	7.625	10.5	12.625	15.75	18	19.375	22.25	24	26.75	31	
	B: Handle Length (in)	4	4	4	4	4	6	6	6	6	6	6	6	6	6	6	6	6	6	6
	C: Handle Width (in)	1	1	1	1	1	1	1.25	1.25	1.25	1.5	1.5	1.5	1.5	1.5	1.5	1.5	1.5	1.5	1.5
	D: Plate Thickness (in)	0.125	0.125	0.125	0.125	0.125	0.125	0.125	0.125	0.125	0.125	0.25	0.25	0.25	0.25	0.375	0.375	0.375	0.375	0.5
ANSI 900	Blank Weight (lb)	0.12	0.21	0.42	CF	0.56	1.03	CF	1.37	2.01	3.87	11.78	16.79	21.95	23.92	43.61	54.2	64.86	125.2	
	A: Plate OD (in)	2.500	2.75	3.125	3.5	3.875	5.625	6.5	6.625	8.125	11.375	14.125	17.125	19.625	20.5	22.625	25	27.375	32.875	
	B: Handle Length (in)	4	4	4	4	4	6	6	6	6	6	6	6	6	6	6	6	6	6	6
	C: Handle Width (in)	1	1	1	1	1	1.00	1.25	1.25	1.25	1.5	1.5	1.5	1.5	1.5	1.5	1.5	1.5	1.5	1.5
	D: Plate Thickness (in)	0.125	0.125	0.125	0.125	0.125	0.125	0.125	0.125	0.125	0.125	0.25	0.25	0.25	0.25	0.375	0.375	0.375	0.375	0.5
ANSI 1500	Blank Weight (lb)	CF	CF	CF	CF	CF	CF	CF	CF	CF	CF	CF	CF	CF	CF	CF	CF	CF	CF	
	A: Plate OD (in)	2.5	2.75	3.125	3.5	3.875	5.625	6.5	6.875	8.25	11.125	13.875	17.125	20.5	22.75	25.25	27.625	29.625	35.5	
	B: Handle Length (in)	4	4	4	4	4	6	6	6	6	6	6	6	6	6	6	6	6	6	6
	C: Handle Width (in)	1	1	1	1	1	1	1.25	1.25	1.25	1.5	1.5	1.5	1.5	1.5	1.5	1.5	1.5	1.5	1.5
	D: Plate Thickness (in)	0.125	0.125	0.125	0.125	0.125	0.125	0.125	0.125	0.125	0.125	0.25	0.25	0.25	0.25	0.375	0.375	0.375	0.375	0.5
ANSI 2500	Blank Weight (lb)	CF	CF	CF	CF	CF	CF	CF	CF	CF	CF	CF	CF	CF	CF	CF	CF	CF	CF	
	A: Plate OD (in)	2.75	3	3.375	4.125	4.625	5.75	6.625	7.75	9.25	12.5	15.25	18.75	21.625	CF	CF	CF	CF	CF	
	B: Handle Length (in)	4	4	4	4	4	6	6	6	6	6	6	6	6	6	6	6	6	6	6
	C: Handle Width (in)	1	1	1	1	1	1	1.25	1.25	1.25	1.5	1.5	1.5	1.5	1.5	1.5	1.5	1.5	1.5	1.5
	D: Plate Thickness (in)	0.125	0.125	0.125	0.125	0.125	0.125	0.125	0.125	0.125	0.125	0.25	0.25	0.25	0.25	0.375	0.375	0.375	0.375	0.5

Dimensions and API Ring Numbers

The Plate Dimension diagrams (Figures 5 and 6 on page 11) demonstrate the plate component measurements that correspond to A, B, and C in Table 9A and and Table 11. All weights are based on the dimensions provided.

Ring-Type Joint (RTJ) Orifice Plate Holders: Models 560 and 590

The Daniel Model 560 is an intergral plate holder & Daniel Model 590 ring-type joint (RTJ) orifice plate holders are fitted with Universal orifice plates (Model 500) and are used with RTJ orifice flange unions. Holding screws secure the plate in the holder, and there is a gasket between the plate and the holder. The orifice plate is not included and must be ordered separately.

Model 560 plate holders are available in all sizes and ring numbers. Model 590 plate holders are available in DN50 (2-in) and larger in all ring numbers with the exception of DN50 (2-in) R-23 and DN65 (2.5-in) R-26 API ring numbers. Consult factory for other sizes, materials, ANSI ratings and special flange ratings.

Table 9A: API Ring Numbers, Dimensional Data and Weights (Metric Units)																		
Ring-Type Joint (RTJ) Plate Holders (Models 560 and 590)																		
Line Size (DN)	15	20	25	40	50	65	80	100	150	200	250	300	350	400	450	500	600	
PN50 to PN100	API Ring Number	R-11	R-13	R-16	R-20	R-23	R-26	R-31	R-37	R-45	R-49	R-53	R-57	R-61	R-65	R-69	R-73	R-77
	ANSI 300 Gap ⁽¹⁾ (mm)	15.875	15.875	15.875	15.875	16.637	16.637	16.637	16.637	16.637	19.812	19.812	19.812	19.812	22.987	22.987	22.987	26.162
	PN50 to PN100 Gap ⁽¹⁾ (mm)	15.875	15.875	15.875	15.875	15.875	15.875	15.875	15.875	15.875	19.05	19.05	19.05	19.05	22.225	22.225	22.225	25.4
	A: (mm)	24.003	26.035	26.035	26.035	28.575	28.575	28.575	28.575	28.575	31.75	31.75	31.75	31.75	34.925	34.925	36.449	42.164
	B: (mm)	107.95	107.95	107.95	107.95	107.95	133.35	133.35	133.35	158.75	158.75	184.15	184.15	184.15	184.15	184.15	184.15	184.15
	C: Ring OD (mm)	40.462	50.8	58.75	76.2	93.675	112.725	134.95	160.35	222.25	281	334.975	392.125	430.225	481.025	544.525	596.9	708.025
	560 Plate Blank Weight (kg)	0.1	0.2	0.3	0.4	0.9	1.1	1.5	2	3.2	4.8	6.5	8.5	9.9	16.1	20.8	25.5	36.7
590 Plate Blank Weight (kg)					0.8	0.9	1.2	1.5	2.1	2.7	3.3	3.8	4.2	5.6	6.4	8	11.8	
PN150	API Ring Number	R-12	R-14	R-16	R-20	R-24	R-27	R-31	R-37	R-45	R-49	R-53	R-57	R-62	R-66	R-70	R-74	R-78
	PN150 Gap ⁽¹⁾ (mm)	15.875	15.875	15.875	15.875	15.875	15.875	15.875	15.875	19.05	19.05	19.05	19.05	22.225	22.225	22.225	25.4	
	A: (mm)	26.035	26.035	26.035	26.035	26.035	26.035	30.353	29.337	29.337	32.512	32.512	32.512	37.338	40.513	42.799	42.799	53.086
	B: (mm)	107.95	107.95	107.95	107.95	107.95	133.35	133.35	133.35	158.75	158.75	184.15	184.15	184.15	184.15	184.15	184.15	234.95
	C: Ring OD (mm)	47.625	52.4	58.75	76.2	106.375	119.075	134.95	160.35	222.25	281	334.98	392.98	434.98	485.78	552.45	603.25	717.55
	560 Plate Blank Weight (kg)	0.2	0.2	0.3	0.4	0.9	1	1.5	2	3.2	4.8	6.5	8.5	12.3	19.3	26.2	29.6	46.6
	590 Plate Blank Weight (kg)					0.8	1.2	1.2	1.5	2.1	2.7	3.3	3.8	6.7	8.6	12.2	12.5	22.5
PN250	API Ring Number	R-12	R-14	R-16	R-20	R-24	R-27	R-35	R-39	R-46	R-50	R-54	R-58	R-63	R-67	R-71	R-75	R-79
	PN250 Gap ⁽¹⁾ (mm)	15.875	15.875	15.875	15.875	15.875	15.875	15.875	15.875	14.351	19.05	19.05	19.05	19.05	22.225	22.225	22.225	25.4
	A: (mm)	26.035	26.035	26.035	26.035	30.353	30.353	30.353	30.353	30.353	37.338	37.338	42.926	46.736	50.927	50.927	52.197	58.674
	B: (mm)	107.95	107.95	107.95	107.95	133.35	133.35	133.35	133.35	158.75	158.75	184.15	209.55	209.55	234.95	234.95	260.35	260.35
	C: Ring OD (mm)	47.625	52.4	58.75	76.2	106.38	119.08	119.08	173.05	223.85	223.85	339.73	339.73	444.5	498.48	561.98	615.95	727.075
	560 Plate Blank Weight (kg)	0.2	0.2	0.3	0.4	0.9	1.2	1.7	2.2	3.7	6.4	8.3	14	18.5	29.2	35.2	42.5	60.2
	590 Plate Blank Weight (kg)					0.8	1	1.3	1.6	2.5	4.3	5.2	9.6	13.2	19.1	21.7	26.2	36.8
PN400	API Ring Number	R-13	R-16	R-18	R-23	R-26	R-28	R-32	R-38	R-47	R-51	R-55	R-60					
	PN400 Gap ⁽¹⁾ (mm)	15.875	15.875	15.875	15.875	15.875	41.275	15.875	15.875	15.875	19.05	19.05	19.05					
	A: (mm)	26.035	26.035	26.035	1.195	30.353	57.277	31.877	34.163	37.211	42.926	49.276	50.8					
	B: (mm)	107.95	107.95	107.95	133.35	133.35	133.35	158.75	158.75	184.15	209.55	209.55	234.95					
	C: Ring OD (mm)	50.8	58.75	68.275	93.675	112.723	123.82	139	173.05	247.65	301.625	371.475	438.15					
	560 Plate Blank Weight (kg)	0.2	0.3	0.3	0.7	1.1	1.5	2.0	3	5.9	9.1	17.1	22.6					
	590 Plate Blank Weight (kg)					1	1.3	1.7	2.5	4.6	7.0	12.1	17.8					

Table 10A: Standard Plate Thickness (Metric Units)	
Ring-Type Joint (RTJ) Plate Holders (Models 560 and 590)	
Plate Size (DN) ⁽²⁾	Thickness (mm)
DN15 to DN150	3.2 mm
DN200 to DN350	6.4 mm
DN400 to DN500	9.5 mm
DN600 and Larger	12.7 mm

Table 10B: Standard Plate Thickness (US Customary Units)	
Ring-Type Joint (RTJ) Plate Holders (Models 560 and 590)	
Plate Size (in) ⁽²⁾	Thickness (in)
0.5 to 6 inch	0.125 inch
8 to 14 inch	0.25 inch
16 to 20 inch	0.375 inch
24 inch and Larger	0.5 inch

- (1) Approximate gap refers to the approximate distance between the flanges.
- (2) DN50 to DN150 (2-in to 6-in) Model 560 plate holders have 6.4 mm (0.25-in) thick plates as standard; add 3.2 mm (0.125-in) to the A dimension and approximate gap for Model 560 holders in these sizes.
- (3) The oval form is standard.

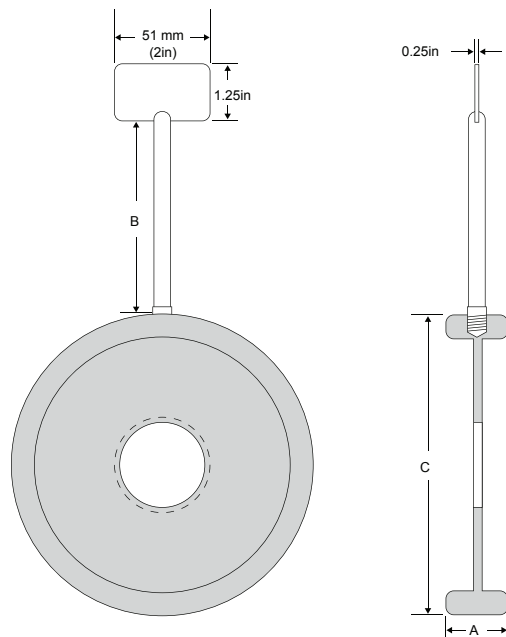

Figure 5: Plate Dimension Diagram for Integral Plate Seal (Model 560)

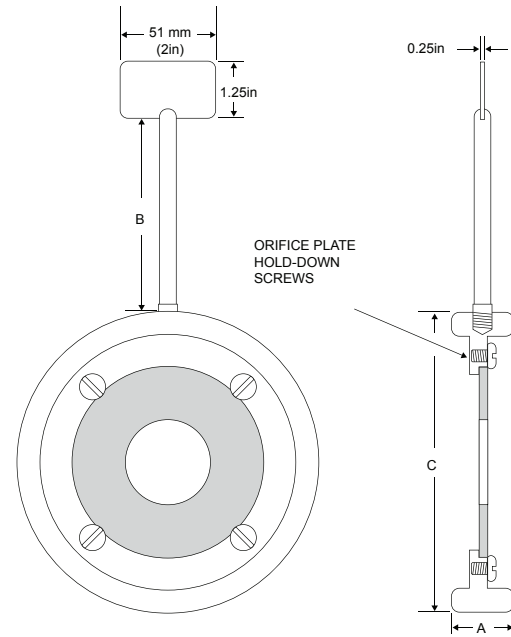

Figure 6: Plate Dimension Diagram for Integral Plate Seal with Hold-Down Screws (Model 590)

Table 11: API Ring Numbers, Dimensional Data and Weights (US Customary Units)																			
Ring-Type Joint (RTJ) Plate Holders (Models 560 and 590)																			
	Line Size (in)	.5	.75	1	1.5	2	2.5	3	4	6	8	10	12	14	16	18	20	24	
ANSI 300 to 600	API Ring Number	R-11	R-13	R-16	R-20	R-23	R-26	R-31	R-37	R-45	R-49	R-53	R-57	R-61	R-65	R-69	R-73	R-77	
	ANSI 300 Gap ⁽¹⁾ (in)	0.625	0.625	0.625	0.625	0.655	0.655	0.655	0.655	0.655	0.78	0.78	0.78	0.78	0.905	0.905	0.905	1.03	
	ANSI 600 Gap ⁽¹⁾ (in)	0.625	0.625	0.625	0.625	0.625	0.625	0.625	0.625	0.625	0.625	0.75	0.75	0.75	0.875	0.875	0.875	1	
	A: (in)	0.945	1.025	1.025	1.025	1.125	1.125	1.125	1.125	1.125	1.25	1.25	1.25	1.25	1.375	1.375	1.375	1.375	1.66
	B: (in)	4.25	4.250	4.25	4.25	4.25	5.25	5.25	5.25	5.25	6.25	6.25	7.25	7.25	7.250	7.25	7.25	7.25	7.25
	C: Ring OD (in)	1.593	2	2.313	3	3.688	4.438	5.313	6.313	8.75	11.063	13.188	15.438	16.938	18.938	21.438	23.5	27.875	
	560 Plate Blank Weight (lb)	0.3	0.5	0.6	0.9	1.9	2.5	3.3	4.3	7.2	10.6	14.3	18.7	21.9	35.6	45.9	56.2	80.8	
590 Plate Blank Weight (lb)					1.7	2.1	2.6	3.2	4.6	5.9	7.2	8.4	9.3	12.3	14	17.7	26.1		
ANSI 900	API Ring Number	R-12	R-14	R-16	R-20	R-24	R-27	R-31	R-37	R-45	R-49	R-53	R-57	R-62	R-66	R-70	R-74	R-78	
	ANSI 900 Gap ⁽¹⁾ (in)	0.625	0.625	0.625	0.625	0.625	0.625	0.625	0.625	0.625	0.75	0.75	0.75	0.75	0.875	0.875	0.875	1	
	A: (in)	1.025	1.025	1.025	1.025	1.025	1.025	1.195	1.155	1.155	1.28	1.28	1.28	1.47	1.595	1.685	1.685	2.09	
	B: (in)	4.25	4.25	4.25	4.25	5.25	5.25	5.25	5.25	6.25	6.25	7.25	7.25	7.25	7.25	7.25	7.25	9.25	
	C: Ring OD (in)	1.875	2.063	2.313	3	4.188	4.688	5.313	6.313	8.75	11.063	13.188	15.438	17.125	19.125	21.75	23.75	28.25	
	560 Plate Blank Weight (lb)	0.4	0.5	0.6	0.9	2	2.7	3.3	4.3	7.2	10.6	14.3	18.7	27.1	42.6	57.8	65.2	102.8	
	590 Plate Blank Weight (lb)					1.8	2.3	2.6	3.2	4.6	5.9	7.2	8.4	14.8	18.9	26.9	27.5	49.7	
ANSI 1500	API Ring Number	R-12	R-14	R-16	R-20	R-24	R-27	R-35	R-39	R-46	R-50	R-54	R-58	R-63	R-67	R-71	R-75	R-79	
	ANSI 1500 Gap ⁽¹⁾ (in)	0.625	0.625	0.625	0.625	0.625	0.625	0.625	0.625	0.565	0.75	0.75	0.75	0.75	0.875	0.875	0.875	1	
	A: (in)	1.025	1.025	1.025	1.025	1.195	1.195	1.195	1.195	1.195	1.47	1.47	1.69	1.84	2.005	2.005	2.055	2.31	
	B: (in)	4.25	4.25	4.25	4.25	5.25	5.25	5.25	5.25	6.25	6.25	7.25	8.25	8.25	9.25	9.25	10.25	10.25	
	C: Ring OD (in)	1.875	2.063	2.313	3	4.188	4.688	5.813	6.813	8.813	11.25	13.375	15.875	17.5	19.625	22.125	24.25	28.625	
	560 Plate Blank Weight (lb)	0.4	0.5	0.6	0.9	2	2.7	3.8	4.9	8.2	14.0	18.3	30.8	40.8	64.4	77.5	93.7	132.8	
	590 Plate Blank Weight (lb)					1.8	2.3	2.9	3.5	5.6	9.5	11.4	21.2	29.1	42.1	47.8	57.8	81.2	
ANSI 2500	API Ring Number	R-13	R-16	R-18	R-23	R-26	R-28	R-32	R-38	R-47	R-51	R-55	R-60						
	ANSI 2500 Gap ⁽¹⁾ (in)	0.625	0.625	0.625	0.625	0.625	0.625	0.625	0.625	0.625	0.75	0.75	0.75						
	A: (in)	1.025	1.025	1.025	1.195	1.195	1.255	1.255	1.345	1.465	1.69	1.94	2						
	B: (in)	4.25	4.25	4.25	5.25	5.25	5.25	6.25	6.25	7.25	8.25	8.25	9.25						
	C: Ring OD (in)	2	2.313	2.688	3.688	4.438	4.875	5.5	6.813	9.75	11.875	14.625	17.25						
	560 Plate Blank Weight (lb)	0.5	0.6	0.7	1.5	2.5	3.3	4.5	6.6	13.1	20.1	37.6	49.8						
	590 Plate Blank Weight (lb)					2.1	2.9	3.7	5.5	10.2	15.5	26.6	39.3						

(1) Approximate gap refers to the approximate distance between the flanges.

Daniel Orifice Plate Selection Options

The following table is intended to provide orifice plate option for each plate category.

Table12: Orifice Plate Options with codes						
Code	Line Size	Model 500	Model 510	Model 520	Model 560	Model 590
50	1/2 inch			X	X	
75	3/4 inch			X	X	
1	1 inch			X	X	
05	1 1/4 inch			X	X	
15	1 1/2 inch			X	X	
02	2 inch	X		X	X	X
25	2 1/2 inch	X		X	X	X
03	3 inch	X		X	X	X
04	4 inch	X		X	X	X
06	6 inch	X		X	X	X
08	8 inch	X		X	X	X
10	10 inch	X		X	X	X
12	12 inch	X	X	X	X	X
14	14 inch	X	X	X	X	X
16	16 inch	X	X	X	X	X
18	18 inch	X	X	X	X	X
20	20 inch	X	X	X	X	X
24	24 inch	X	X	X	X	X
XX	Other	CF	CF	CF	CF	CF
Plate Holder Style						
A	Oval				X	X
B	Octagonal				X	X
Bore Type						
A	Bore & Bevel (Concentric)	X	X	X	X	
B	Bore & no bevel (Concentric)	X	X	X	X	
C	Bore & Counter Bore	X	X	X	X	
D	Segmental	X	X	X	X	
E	Eccentric	X	X	X	X	
F	Quadrant round	X	X	X	X	
G	Blank	X	X	X	X	
X	Other	CF	CF	CF	CF	
Bore Treatment						
SB	Stellite Bore Edge	X	X	X	X	
NA	None	X	X	X	X	
Vent /Drain						
V	Vent	X	X	X	X	
D	Drain	X	X	X	X	
B	Vent & Drain	X	X	X	X	
N	None	X	X	X	X	
Plate Thickness						
18	1/8 inch	X		X		X
14	1/4 inch	X	X	X	X	X
38	3/8 inch	X	X	X	X	X
12	1/2 inch	X	X	X	X	X
01	01-1/4 inch with 1/8 recessed edge	X				
02	02-3/8 inch with 1/4 recessed edge	X				
03	03-1/2 inch with 3/8 recessed edge	X				
XX	Other	CF	CF	CF	CF	CF

Daniel Orifice Plates and Plate Sealing Units

Table 12: Orifice Plate Options with codes (continued)						
		Model 500	Model 510	Model 520	Model 560	Model 590
Plate Finish						
A	≤ 30 micro-inch roughness			X		
B	Serrated face 125 to 250 RMS			X		
X	Other			CF		
Handle Dimensions						
A	Standard			X		
B	Other			CF		
Material of Construction of Plate						
M1	316/316L	X	X	X		
M3	Monel 400	X	X	X		
M4	HAST-C276	X	X	X		
M5	Titanium	X	X	X		
M6	Duplex ASTM A-240, UNS S31803	X	X	X		
XX	Other	CF	CF	CF		
Material of Construction of Plate Holder						
M1	316/316				X	X
M3	Monel 400				X	X
M4	HAST-C276				X	X
M5	Titanium				X	X
M6	Duplex ASTM A-240, UNS S31803				X	X
XX	Other				CF	CF
Pressure Rating						
01	ANSI 150	X	X	X	X	X
03	ANSI 300	X	X	X	X	X
05	ANSI 600	X	X	X	X	X
06	ANSI 900	X	X	X	X	X
07	ANSI 1500	X	X	X	X	X
08	ANSI 2500	X	X	X	X	X
XX	Other	CF	CF	CF	CF	CF
Measurement Code						
A	API 14.3	X	X	X	X	X
I	ISO 5167	X	X	X	X	X
X	Other	CF	CF	CF	CF	CF
Seal Material						
A	NBR		X			
B	HNBR		X			
C	FKM		X			
X	Other		CF			
Gasket Material						
A	Standard					X
X	Other					CF
Factory Options						
Z	Standard Product	X	X	X	X	X
X	ETO Product	X	X	X	X	X

Note: Order details and materials will be confirmed upon receipt.

Emerson Automation Solutions

Daniel Measurement and Control, Inc.
North America / Latin America:
Headquarters
USA - Houston, Texas
T +1.713.467.6000
USA Toll Free 1.888.FLOW.001

Europe: Stirling, Scotland, UK
T +44.1786.433400
Middle East, Africa: Dubai, UAE
T +971.4.811.8100
Asia Pacific: Singapore
T +65.6777.8211

www.Emerson.com/Daniel

©2017 Daniel Measurement and Control, Inc. All Rights Reserved. Unauthorized duplication in whole or in part is prohibited. Printed in the USA. DAN-Orifice Plate-and-Plate-Sealing-Units-DS-1017

The Emerson logo is a trademark and service mark of Emerson Electric Co. Daniel Measurement and Control, Inc. ("Daniel") is an Emerson Automation Solutions business unit and a subsidiary of Daniel Industries, Inc. The Daniel name and logo are trademarks of Daniel Industries, Inc. All other trademarks are the property of their respective companies.

DANIEL™

